

Capacitor Sounds 6 - 10 to 100 μ F capacitors and 100 Hz measurements.

Updated & expanded March 2003

Original version Pub. Electronics World Jan 2003 - C. Bateman

Readers of my articles have now seen that many capacitors introduce distortions onto a pure sinewave. In some instances this distortion results from the unfavourable loading the capacitor imposes onto its valve or semiconductor driver. More often, the capacitor generates the distortion within itself.

For 1 μ F, the lowest distortions are generated by choosing a film capacitor or a Bi-polar electrolytic. Polar aluminium electrolytics produced considerably larger distortions, even when tested with small AC signals. **Ref. 1**

While high capacitance, low cost, electrolytic capacitors, can be obtained from distributors. Low cost metallised film capacitors are restricted typically to 10 μ F at 100 volt and 22 μ F at 63 volt.

In this final article, which completes last months discussion on electrolytic capacitors, we explore whether a metallised film capacitor or an electrolytic is our economic, low distortion choice, for capacitors at 10 μ F to 100 μ F values.

Test frequency.

To avoid overstressing large value electrolytic capacitors, we should reduce our test signal frequency towards 100 Hz. But sufficiently above or below this frequency, to discriminate between harmonics of the supply mains and the test capacitor.

With minor changes in capacitance values, the PCB used for our 1 kHz oscillator can provide an exceptionally low distortion 100 Hz test signal. **Ref. 2** In similar fashion the PCB used for our 1 kHz notch filter and pre-amplifier can also be used at this frequency. **Ref. 3**

The AD811 low distortion buffer can output 40 mA. At 100 Hz using a 100 Ω series resistor, it can develop a 5 volt test signal across a 10 μ F capacitor. Using a 10 Ω resistor, 0.5 volts could be developed across a 100 μ F capacitor.

These test voltages are more than sufficient to distortion test any electrolytic capacitor up to 100 μ F. However when I designed the test instruments I decided to provide the ability to measure both values of film capacitors to 5 volts. To produce a larger test signal with 100 μ F capacitors, a more powerful buffer must be used. A low distortion circuit able to drive up to 400 mA has been designed but needs a different PCB. see **Fig. 1**

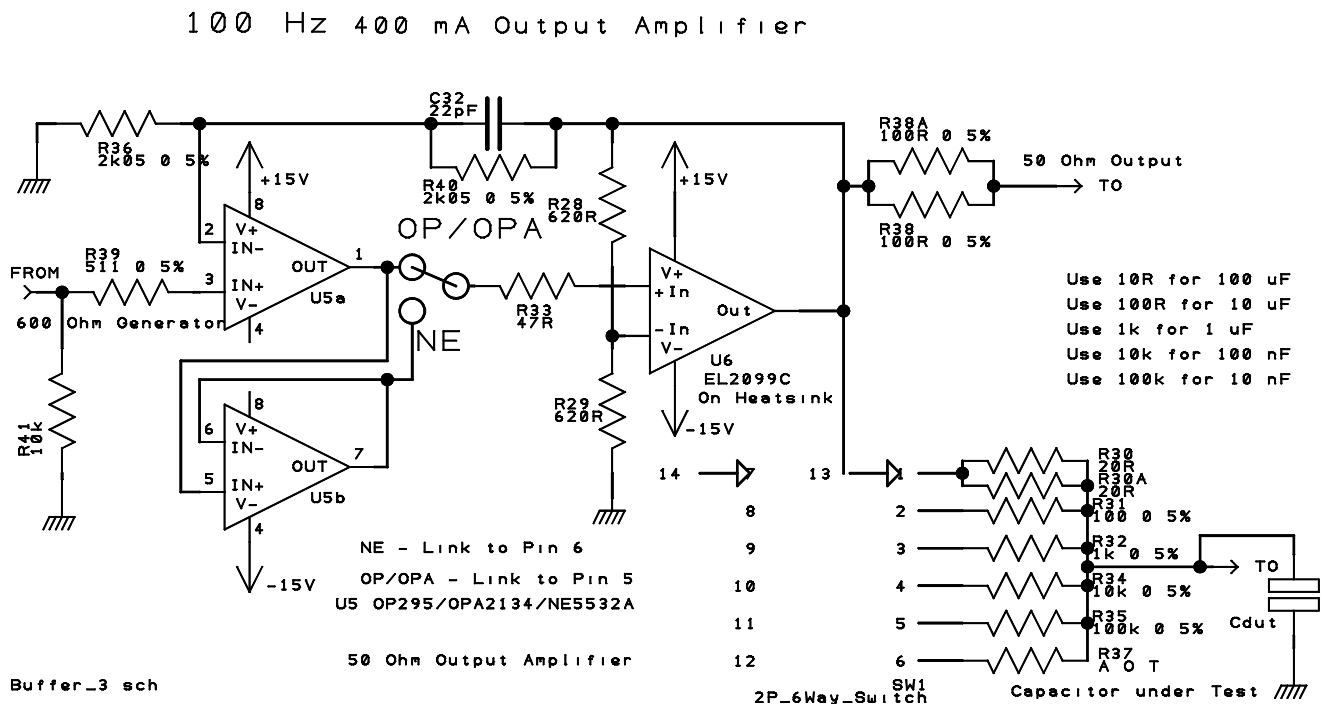

Fig. 1) High power buffer provides low distortion, a gain of two and a 400 mA output. It can develop more than five volts across a 100 μ F capacitor via a 10 Ω current limiting resistor.

When testing large value capacitors, a four terminal test system is preferred. Four BNC connectors are provided, which accept either Hewlett Packard capacitor test jigs or four discrete cables and crock clips. see **Fig. 2**

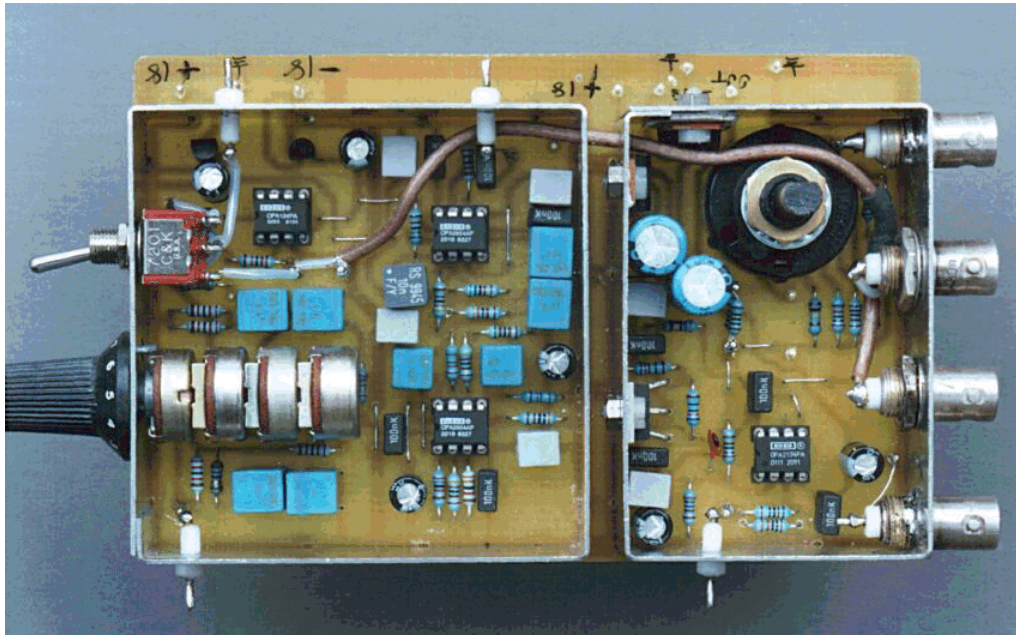

Fig. 2) The higher power 100 Hz test system. Four BNC connectors, are arranged to accept Hewlett Packard test jig fixtures.

The DC bias network inserts between this buffer amplifier and the test jig fixture.

Alternately instead of the Hewlett Packard test jigs, this buffer amplifier can be used with four BNC test leads fitted with 'crock' clips.

Box 100 Hz test equipment.

The oscillator and notch filter printed boards can be used at other frequencies by scaling the values of a few capacitors. **Ref. 2**

Oscillator board.

For 100 Hz use 100 nF 1% metallised Polypropylene for C1, C2, and C3. Bypass R16 by a wire link. To differentiate between test capacitor and mains frequency harmonics, replace R23, R24 and R25 with wire links.

Notch filter/pre-amplifier board.

For 100 Hz use 100 nF 1% metallised Polypropylene for C41, C42, C43, C44, C47 and C48. Use 47 nF 1% metallised Polypropylene for C45 and C46. Use 10 nF 1% metallised Polypropylene for C49.

Output Buffer.

At 100 Hz, 10 μ F capacitors can be tested to 5 volts, using the AD811 output buffer amplifier described. **Ref. 3** Adding a 10 Ohm current limiting resistor allows 100 μ F to be tested to 0.5 volts.

To fully test 100 μ F capacitors, a higher power buffer amplifier is needed. It should develop at least 5 volts signal across a 100 μ F capacitor via a 10 Ohm current limiting resistor. I designed a buffer amplifier and printed circuit board, able to drive up to 7 volt or 400 mA, with extremely low distortion. An Elantec EL2099CT output amplifier is used with an input buffer. This can be an OP295, OPA2134 or an NE 5532A, by connecting one link.. I used an OPA2134 in my prototype. see **Fig. 1**

Larger decoupling capacitors are used with 1.5 Amp stabilisers. A Perancea 75 by 50 mm PCB case serves as heat sink for the EL2099CT and the stabilisers. Apart from these changes, the buffer amplifier schematic circuit and the current limiting resistors/switch follow the approach previously used for my 1 kHz AD811 output buffer.

When testing 100 μ F, a four wire test method should be used. Four BNC connectors, two to output the test current and two to measure the capacitor distortions, are spaced at 22 mm centres to fit Hewlett Packard capacitor test jigs alternately four discrete BNC cables and crock clips can be used.

To measure capacitors larger than 10 μ F with DC bias voltage, a DC blocking buffer circuit as already described but made with larger capacitors is essential.

Two 50 μ F 450 volt metallised Polypropylene motor run capacitors, replaced the 11 μ F current carrying capacitors of my 1 kHz design. Three 3.3 μ F MKP capacitors provide 10 μ F for the voltage measuring circuit. These components were mounted in a die-cast box and hardwired.

Four BNC connectors, were mounted on opposite sides of this box, to mate with my 100 Hz output buffer amplifier and the Hewlett Packard capacitor test jigs. see **Fig. 2**

A selectable DC bias voltage was provided, by mounting 20 AA cells and a range switch, in a second die cast box. This was used with both DC blocking buffer designs.

Tantalum bead capacitors.

Some audio power amplifier designs have used small Tantalum bead capacitors, with apparent success. Initial measurements of a number of Tantalum capacitors revealed large distortions. Measured at 0.3 volts with and without DC bias, my Tantalum capacitor stocks produced at least ten times more distortion than found with low cost polar Aluminium electrolytics. I decided to exclude Tantalum bead capacitors from further tests. see **Fig.3**

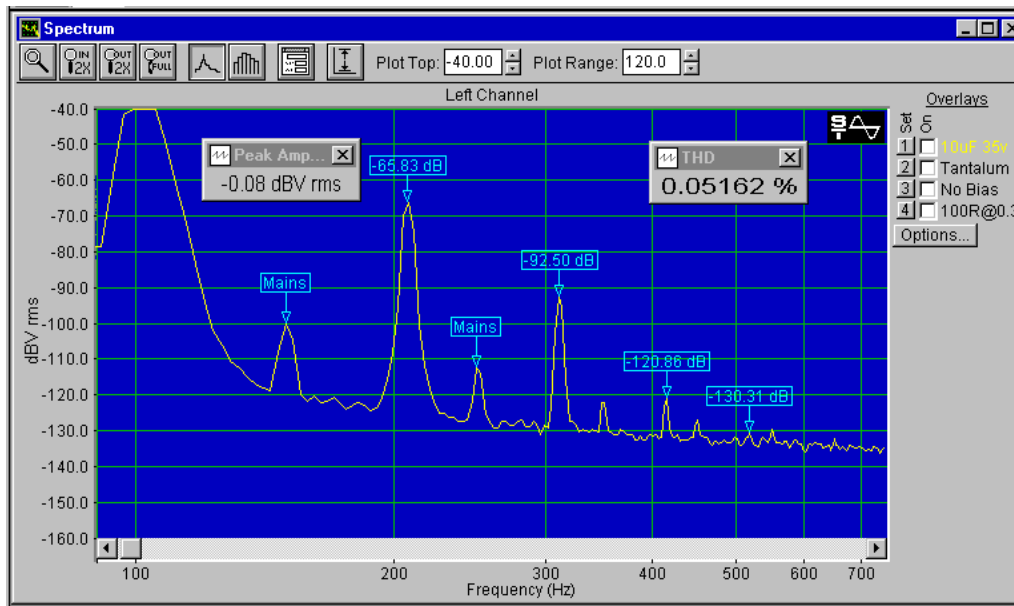

Fig. 3) Distortion of this Tantalum bead capacitor, is ten times worse than found with similar value and voltage aluminium electrolytic capacitors.

Distortion does reduce slightly with application of DC bias.

Aluminium Electrolytic capacitor myths.

As with other capacitor types, much has previously been written about the sound distortions electrolytics produce. As a result, many false myths, specific to electrolytics have emerged. Most were discussed in my last article, the remainder in this.

- High ESR Electrolytics degrade sound quality, low ESR is always best.
- Electrolytics are highly inductive at audio frequencies.
- Polar electrolytics should be biased to half rated voltage to reduce distortion.
- Electrolytic capacitor distortion is mostly third harmonic.

A working knowledge of aluminium electrolytic capacitor construction combined with careful measurements, leads to somewhat different conclusions.

Is a low ESR/tan δ capacitor always better ?

Capacitor makers test every production capacitor for four key parameters. Capacitance, tan δ , insulation resistance and voltage withstand. The need to test for capacitance, insulation resistance and voltage withstand is obvious, but why test tan δ ?

The most nearly perfect capacitor needs conducting electrodes, which inevitably have some resistance. This appears in series with the capacitive reactance to degrade the theoretical -90° of phase difference to a smaller negative angle. As a result the complementary angle called δ (delta) increases. Every practical capacitor also incurs losses in its insulators and dielectric system. These further degrade this phase difference, increasing the angle δ .

The ratio of these resistive losses to the capacitors reactance or tan δ is the simplest way to monitor capacitor quality. As losses increase so does this ratio and the tangent of the angle δ , usually called tan δ . Consequently a large tan δ implies large resistive losses. These losses do not exist as discrete resistors so are described as 'equivalent series resistance' conveniently abbreviated to ESR. Tan δ and ESR are not finite values but do vary widely with change of measurement frequency.

The most nearly perfect capacitor would exhibit near zero ESR. Low ESR is essential for use in switched mode power supplies, but does a low ESR electrolytic ensure low audio distortion ?

Of the 100 μF capacitors I tested, the 10 volt Oscon measured the lowest 100 kHz ESR of all, 0.012 Ω and 100 Hz tan δ of 0.035. It would be unreasonable to compare a 10 volt capacitor with higher voltage types so I also measured 10 volt Rubycon YXF and Elna RSH types. The YXF ESR measured 0.550 Ω , tan δ 0.091. The RSH ESR was 0.505 Ω and tan δ 0.104.

Tested at 0.5 volt with and without 6 volts DC bias, the Rubycon YXF produced the least distortion, 0.0351% with DC bias and 0.00331% unbiased. The Oscon distorted worst of the three, measuring 0.05321% with DC bias and 0.02499% unbiased.

Clearly low tan δ at 100 Hz and low ESR at 100 kHz does not ensure low audio distortion.

Are Electrolytics Inductive at audio frequencies?

Radial lead electrolytics are assembled with their connecting tabs attached towards the centre of their anode and cathode foils. Wound together this produces a near non-inductive winding. As explained in my last article, the main contribution to the capacitor's self inductance then comes from the connecting leadwires and tabs, and not the wound element. **Ref. 4**

This 'inductive at audio frequencies' myth is easily proved to be false. The largest capacitor I measured for distortion, the Nitai 220 μF 63 volt Bi-polar, has a case size 25x16 mm. Apart from in the power supply, this is the largest value commonly used in an audio system. I mounted one on a test jig, its self resonant frequency was 250 kHz, well above audible frequencies. **Ref. 5**

At all audio frequencies this capacitor must present a capacitive reactance. Self inductance of a lesser value or smaller case size radial lead capacitor being even less, self resonance of smaller capacitors will occur at higher frequencies. They cannot become inductive at audio frequencies.

Exceptionally large value capacitors, as often used in power supplies, may appear as either inductive or capacitive depending on their capacitance value, case size and their connecting leadwires/tracks. Inductance of the leadwires/circuit tracks used to connect the capacitor, usually well exceed that of the capacitor's own self inductance. Due to its internal series resistance or ESR the capacitor's phase angle will be much smaller than -90° and the capacitor will appear to the circuit as a series combination of a resistor with a capacitor or as a DC blocking inductance in series with a resistor.

Using a Wayne Kerr B6425 precision LCR meter fitted with my Hewlett Packard capacitor test jigs, I measured a few capacitors removed from one of my old bench amplifiers at 10 kHz, as representative of capacitors which may be used in amplifier power supplies, to illustrate the point:-

Elna 4,700 μF 63 volt Cerafine size 82 mm by 35 mm dia, phase angle $+7.5^\circ$, ESR 11.05 $\text{m}\Omega$ Impedance 18.3 $\text{m}\Omega$
 Marcon 4,700 μF 63 volt size 30 mm by 40 mm dia, phase angle -6.5° , ESR 16.65 $\text{m}\Omega$ Impedance 16.69 $\text{m}\Omega$
 Marcon 10,000 μF 63 volt size 42 mm by 65 mm dia, phase angle -14.5° , ESR 9.68 $\text{m}\Omega$ Impedance 10.0 $\text{m}\Omega$

At 20 kHz both Marcon types remained as a capacitive reactance having a negative phase angle. At 100 kHz the Elna measured as an 83 nH inductor, the 4700 μF Marcon as a 26 nH inductor while the 10,000 μF Marcon measured as a 256 μF capacitor.

This last value shows why it is not possible to estimate capacitor self inductance from published impedance/frequency curves. As frequency increases, the capacitance of all aluminium electrolytic capacitors reduces, some more quickly than others. As the capacitive reactance reduces with frequency, the capacitors ESR becomes almost a constant value. Phase angles become small and the impedance curve becomes 'flat bottomed'. see **Fig. 4**

Any calculation of resonant frequency based on using the correct self inductance value together with this capacitors nominal 10,000 μF value, obviously produces a very false result.

Measured using the Wayne Kerr B6425 with Hewlett Packard test jigs as above, this Philips 1000 μF capacitor exhibited a -6° phase angle and 820 μF capacitance at 30 kHz. At this frequency ESR measured 61.5 $\text{m}\Omega$, impedance was 61.6 $\text{m}\Omega$.

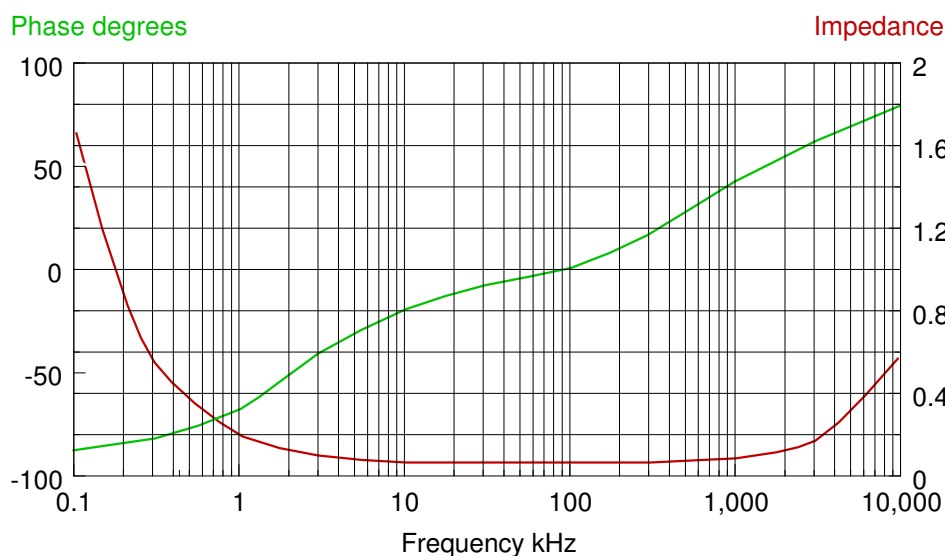

Phase v Impedance

1000 μF 25v Philips 135 Capacitor.

Fig. 4) This 1000 μF 25 volt capacitor has been measured using two quite different methods.

The Wayne Kerr bridge up to 300 kHz, its maximum frequency.

This graph was plotted up to 10 MHz from results using my 'High-frequency impedance meter' with jigs and methods as in EW January 2001.

As can be seen both methods gave almost identical results.

Polar electrolytics.

In my last article we saw that every polar aluminium electrolytic capacitor comprises two polar capacitors in series, back to back. **Ref. 1** Wound with an anode and cathode foil, each foil with the electrolyte, comprises one capacitor. The cathode foil provides a larger capacitance, lower working voltage, than the anode foil.

With no bias voltage, the capacitor produced predominantly second harmonic distortion. In some instances, application of a very small optimum DC bias did minimise this second harmonic. Increased bias however resulted in increased second harmonic distortion.

For the 100 μF 25 volt capacitors tested for this article, optimum bias varied by capacitor, from 1.1 to 4.2 volts. Optimum bias voltage varies with capacitor rated voltage, capacitance value and even from capacitor to capacitor within a small batch. However the important point is that with all the polar aluminium electrolytic capacitors I tested, (several hundred in all) this optimum low distortion bias with no exceptions, was a small voltage. Not the half rated voltage as commonly suggested.

Bi-polar electrolytics.

A Bi-polar electrolytic is made in exactly the same way as a polar capacitor, with one important difference. In place of the unformed cathode foil we use a second, formed, anode foil.

We still have two polar capacitances in series, back to back, both now the same value and voltage. To make the desired value, two anode foils of double capacitance are used.

Aluminium electrolytic capacitor designers are accustomed to mixing and matching their available materials, to suit the capacitor's end application. So it should not surprise that some designs are semi Bi-polar, i.e. they are made using a lower voltage deliberately 'formed' anode foil as cathode.

Equivalent circuit.

Using this constructional background, we deduced an equivalent circuit for a polar aluminium electrolytic capacitor. see **Fig.5**

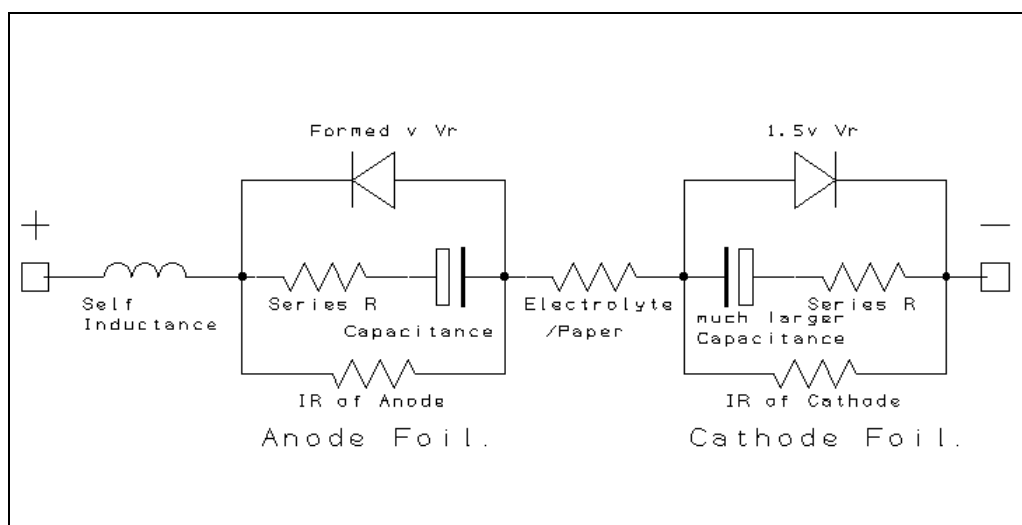

Fig 5) Simplified equivalent schematic shows how a polar electrolytic capacitor behaves with AC signals, with and without DC bias.

Dielectric Oxide. Aluminium oxide has a 'k' of eight, similar to that of COG ceramics or some impregnated paper capacitors.

Ref. 6 It is higher than PET, which at 3.3, has the highest 'k' of commonly used film dielectrics. It is a low value compared to the 'k' of some thousands, found in 'high k' BX, X7R and Z5U ceramics.

More significant is dielectric thickness. Aluminium electrolytic dielectric is much thinner than used in other capacitors and the dielectric oxide film has a small but easily measured voltage coefficient of capacitance, typically +0.1% with +18v DC bias, but this is overshadowed many times by its much larger dielectric absorption. An electrolytic capacitor is exceptionally sensitive to dielectric absorption effects and the applied AC and DC voltages.

Voltage effects.

When our 1 μF 63 volt polar electrolytic was tested using two 0.7 volt frequencies, its third harmonic was -110 dB or 0.0003%. It created visible intermodulation distortion. We also noted small capacitors rated at 40 to 63 volt exhibit near optimum quality.

Ref. 1

Many 100 μF capacitors will be made with lower voltage, thinner dielectric oxide, anode foil. This capacitance requires lengthy anode and cathode foils, housed in a larger diameter can. To generate the test voltage across the capacitor, increased current must pass through the tab connections into the winding, amplifying the affects of any non-linear resistance. It seems probable that similar harmonic and intermodulation levels will be found but at smaller test voltages.

To allow direct comparison between the low cost 1 μF 63 volt polar capacitor and the physically larger Elna Silmic 100 μF 25 volt, I show its distortions measured at 1 volt. This capacitor provided the best 1 volt, no bias, results of the 100 μF polar types tested for this article. see **Fig. 6**

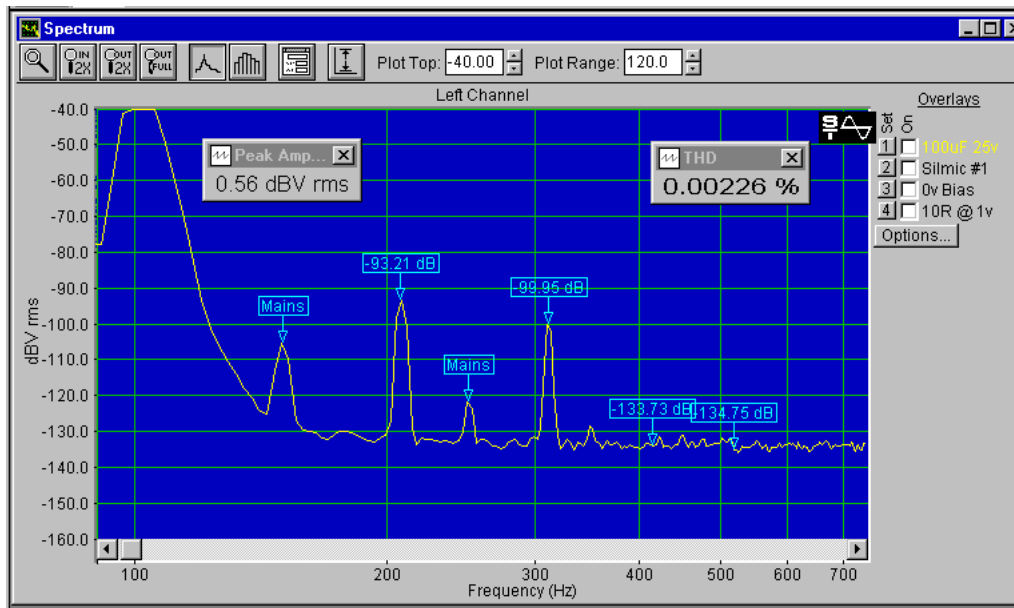

Fig 6) The lowest distorting 100 μF 25 volt polar capacitor of those tested, at 1 volt. It should be compared with Figure 6 (Fig 7 as published in EW) of my last article.

Both capacitors produced similar second harmonics. Third harmonic of the 100 μF has increased by 4.5 dB indicative of increasing non-linearity with increasing capacitance values.

Lower voltage measurements.

Accurate 100 Hz distortion measurements using test signals smaller than 1 volt become quite difficult, for two main reasons.

Supply mains harmonics intrude everywhere and are difficult to reduce using a computer based system.

The smaller test signal reduces the dynamic range of our measurement, dramatically inflating indicated distortion.

For example, using a 0.1 volt test signal, my noise floor is around -112 dB, hence a perfect capacitor producing no distortion at all will still register some 0.0005%. However if we compare the measured harmonic levels of our electrolytic with those found for the identical measurement using a metallised film capacitor. We will see any increase in distortion caused by the electrolytic capacitor.

To distinguish between harmonics from the mains and the test capacitor, my test frequency was displaced a few Hz away from 100 Hz. The Spectra software then ignores mains harmonics when calculating distortions. To assist visual identification, I used 'Mains' markers to identify mains harmonics and amplitude markers to indicate the first four harmonics from the test capacitor.

At 100 μF , a metallised Polypropylene capacitor is both large and costly. I used an assembly of 10 μF Evox Rifa MMK metallised PET capacitors. This works well for small test voltages as a low distortion 'reference' capacitor. see **Fig. 7**

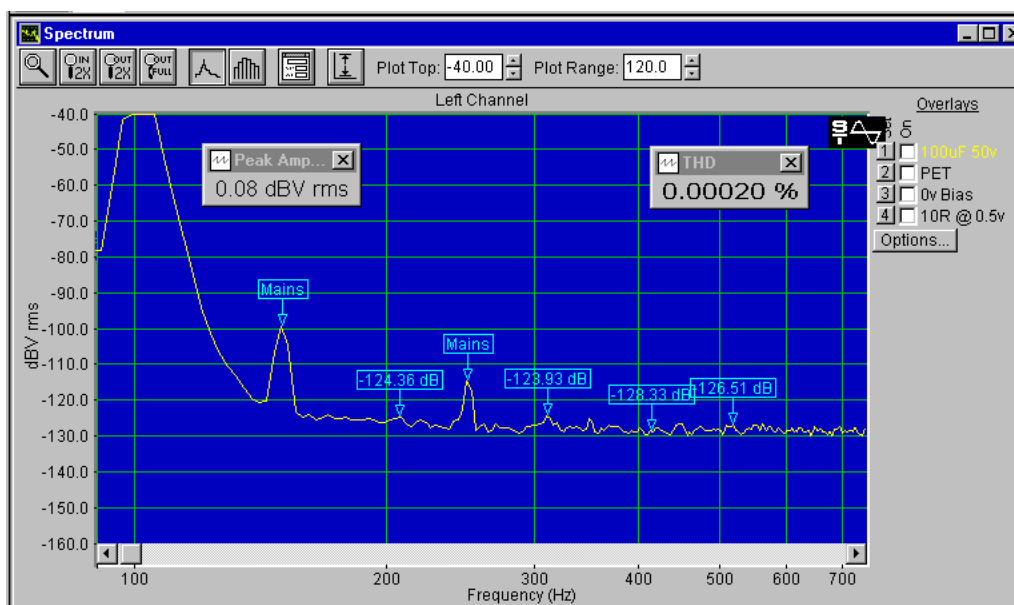

Fig. 7) Distortion plot of an assembly of ten Evox Rifa 10 μF 63 volt MMK metallised PET capacitors, tested at 0.5 volt.

This 100 μF assembly was then used as the distortion reference for each 100 Hz low voltage distortion test.

N.B. Labels 'Mains' indicate 150 and 250 Hz harmonics of the 50 Hz AC supply mains.

Electrolytic distortion.

Despite some marketing claims, capacitors are not categorised for distortion so a distorting capacitor would not be considered defective by its maker. It is the responsibility of the equipment designer to select the correct capacitor for each circuit.

During this investigation I measured many other polar electrolytic capacitors, rated from 10 to 100 volt and with capacitance ranging from 1 to 220 μF , produced by several different, major manufacturers.

To illustrate this article, I decided to measure three quite different 100 μF 25 volt polar electrolytic capacitors and my metallised PET assembly. The low cost Rubycon YXF, typical of a modern miniature low ESR capacitor, the much larger and more expensive Elna Silmic and the considerably more expensive Black Gate FK, physically larger than the Elna Silmic.

The Black Gate FK is a 21 \times 10 mm semi Bi-polar, built using a low voltage anode as its cathode foil. The Silmic is 17 \times 10 mm and uses a special separator paper incorporating silk extracts. Both were purchased from Audiocom UK.

The Rubycon YXF is a 12 \times 6.5 mm conventional, miniature, low ESR low cost capacitor purchased from Farnell.

Tests were performed using 0.1 volt AC to 0.5 volt AC in 0.1 volt steps, each using DC bias voltages of 0 volt, 6 volt, 12 volt and 18 volt, a total of 65 separate distortion measurements.

100 μF 25 volt tests.

With the 0.1 volt test signal, measurement noise floor was reduced to -112 dB. With no bias, distortions for the PET reference capacitor and the Black Gate FK were lost in this noise. Second harmonic for the Silmic measured -106.1 dB and the YXF measured -102.8 dB.

With 6 volt DC bias, second harmonic for the Black Gate FK measured -99 dB, the Silmic measured -99.5 dB and the YXF measured -93.5 dB.

With 12 volt DC bias, second harmonic for the Black Gate FK increased to -95.9 dB, the Silmic was -94.4 dB and the YXF measured -91.8 dB.

With 18 volt DC bias, second harmonic for all three electrolytic capacitors increased again to -93.6 for the Black Gate, -91.3 for the Silmic and -90.0 for the YXF. Distortions now measured some three times greater than the PET assembly. see **Fig.8**

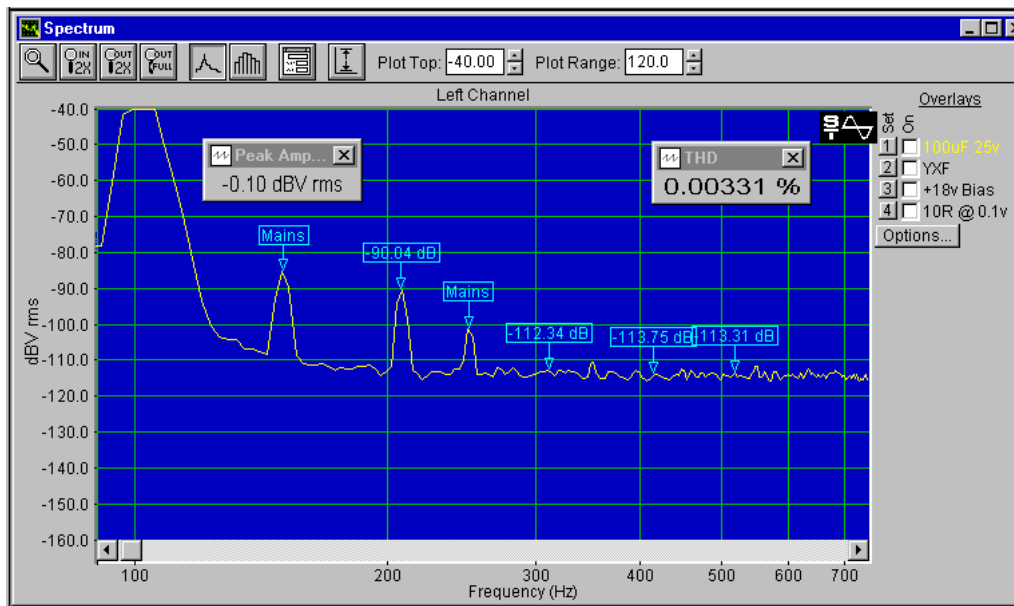

Fig. 8) Distortion of a low cost, very small Rubycon YXF capacitor, tested at 0.1 volt with 18 volt DC bias, was less than 50% worse than the two larger, more expensive capacitors.

0.2 Volt Tests.

Using a 0.2 volt test signal, the measurement noise floor improved to -118 dB. With and without bias, all electrolytic distortions increased more than the change of test signal. With no bias the Silmic performed best of the three polar electrolytics, outperforming the Black Gate FK by almost 6 dB. **Fig. 9 B, C**

With 18 volts DC bias, dielectric absorption effects increased the second harmonic of the Silmic by 21.7 dB and its distortion to 0.0054%. The Black Gate was less affected and its distortion increased to 0.0037%. The YXF distorted rather more, at 0.0063%.

Third harmonic distortions were visible above the noise floor, but not sufficient to produce measurable intermodulation distortion.

0.2 volt tests with 0 volt DC bias:-

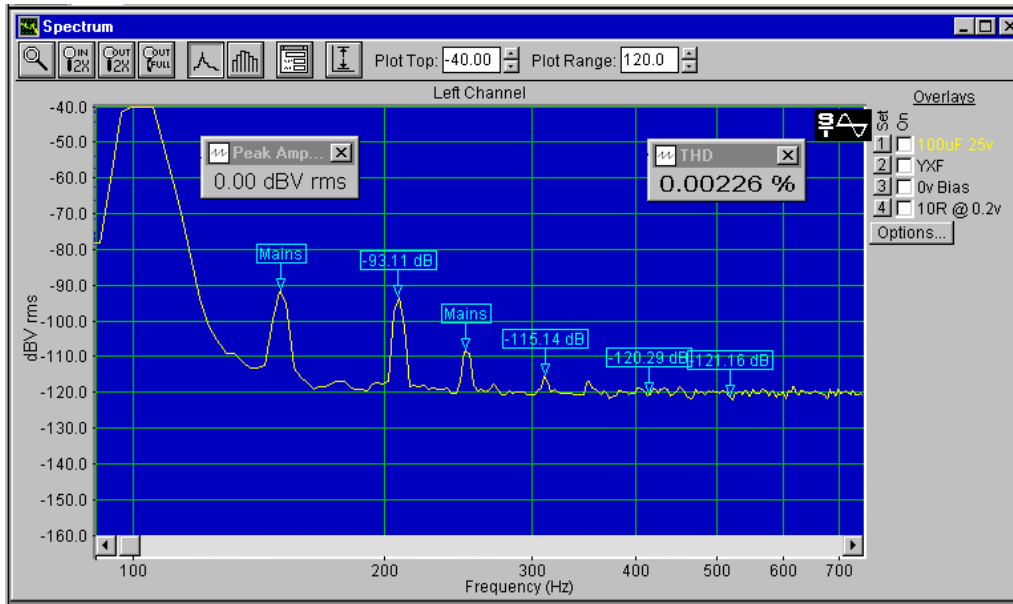

Fig 9A) With second harmonic at -93.11 dB, third at -115.14 dB, this very low cost, miniature electrolytic produces near 3 times more distortion than the more expensive specialist capacitors.

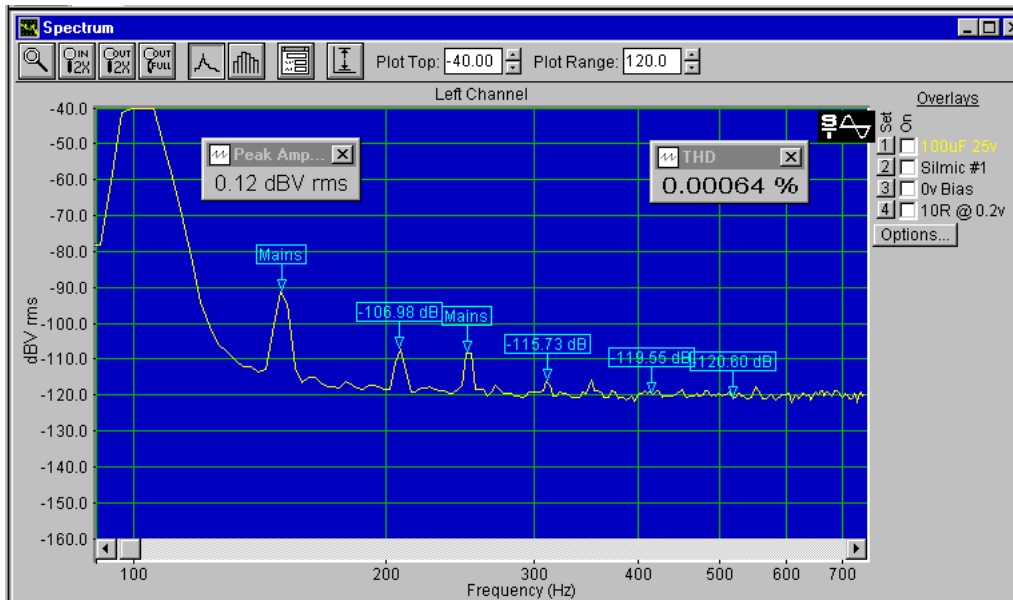

Fig 9B) This specialist audio capacitor 'Silmic' from Elna provides the best no bias distortion of the three types tested at 0.2 volts.

However it produces much larger distortions than measured for the reference capacitor.

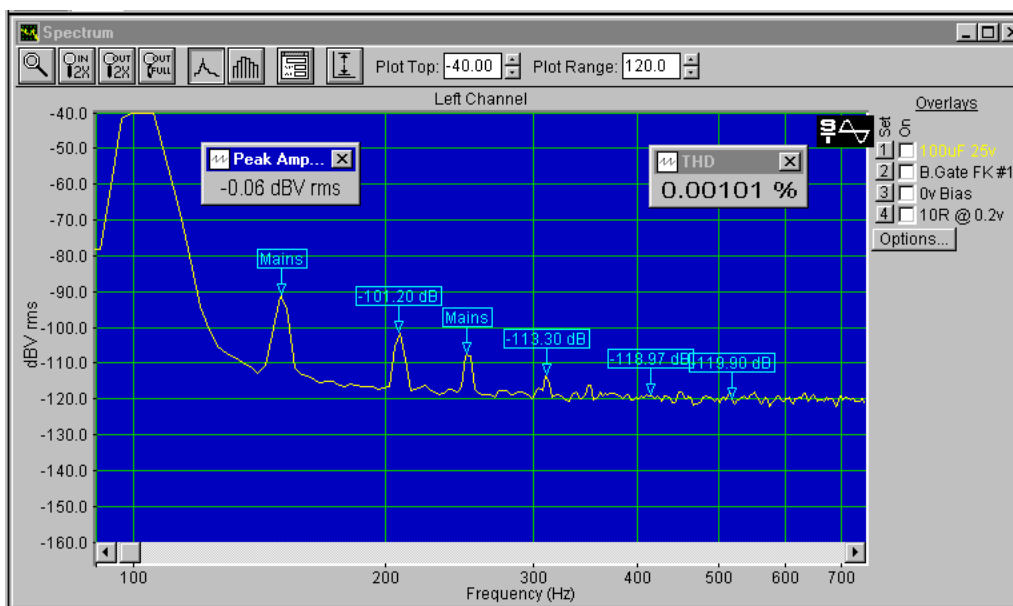

Fig 9C) This specialist audio capacitor the Black gate-FK, produces almost 6 dB more second harmonic than the Silmic when tested at 2 volts with no DC bias.

Tested using 6 volts DC bias, the Silmic and Black Gate capacitors produced almost identical second harmonic distortions at -93.6 and 93.8 dB respectively. Measured distortion for both was 0.0021%. The YXF second harmonic was at -90.52 dB.

0.2 volt tests with 18 volt DC bias:-

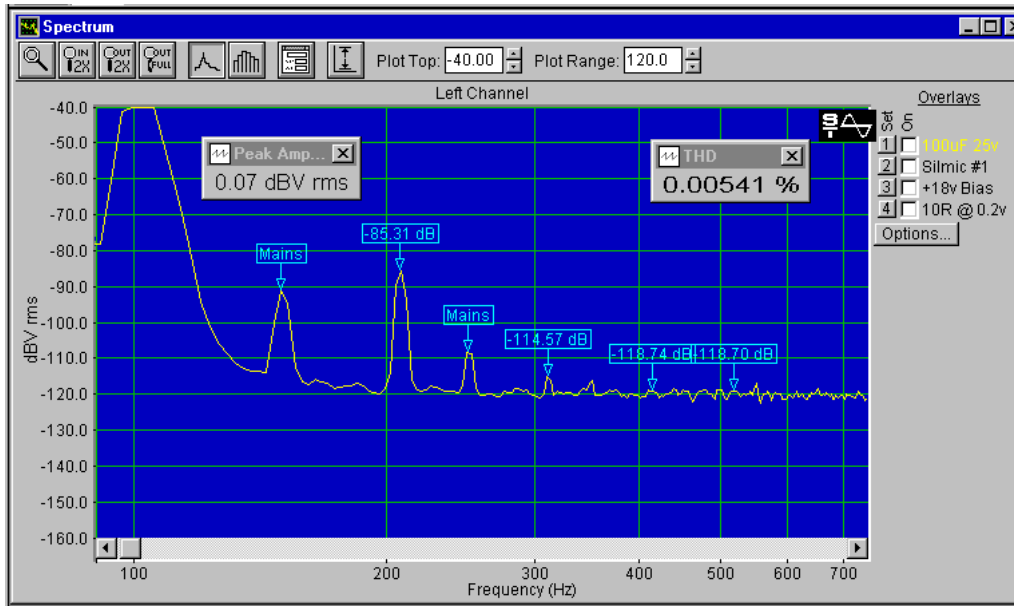

Fig 9D) Measured with 18 volt DC bias, second harmonic for the Silmic increased by almost 22 dB to -85.3 dB, third remained at -114.6 dB. Distortion is now 0.00541%.

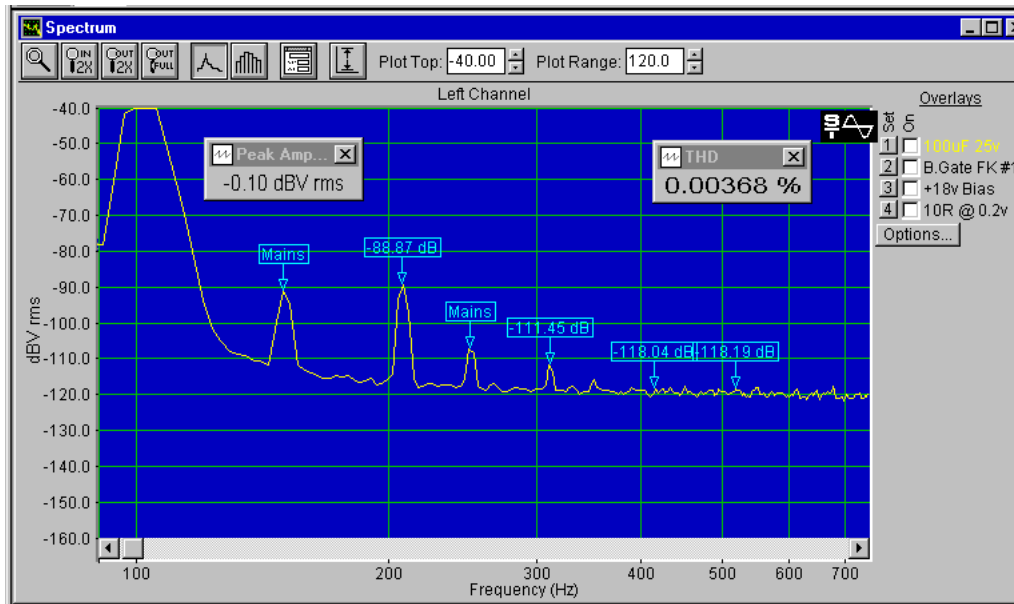

Fig 9E) Measured with 18 volt DC bias, second harmonic for the Black Gate-FK increased rather less, by some 12 dB to give -88.8 dB, third remained at -111.5 dB. Distortion is now 0.00368%.

With 18 volts bias this Black Gate FK has now become the better capacitor.

However the reference capacitor harmonics remain lost in the noise floor.

0.3 Volt Tests.

With a 0.3 volt test signal, measurement noise floor improved to -123 dB but the PET reference capacitor harmonics remain buried in noise. Second and third harmonics of the polar capacitors are now clearly visible, their distortions having increased much faster than the test signal level.

With a 0.3 volt test signal and no bias, the Silmic, at 0.00098%, produced the least distortion of the three electrolytics. Its second harmonic measured -100.6 dB, Black Gate -98.5 dB and YXF -89.1 dB. This is the best electrolytic of those I tested with no bias, however it still produced more than three times the distortion of the PET assembly. **Fig.7**

With 6 volt DC bias, the Silmic and Black Gate, with second harmonics around -90 dB, produced similar 0.003% distortion. The YXF second harmonic was -87.3 dB for 0.0043% distortion.

With 18 volt DC bias the Black Gate develops fifteen times more distortion than the PET assembly but now distorts less than the other two electrolytics. Its second harmonic at -84.1 dB was some 3 dB better than the Silmic and 4 dB better than the low cost YXF type. Distortions now measured 0.00637%, 0.00840% and 0.00951% respectively. **Fig. 10 I**

Third harmonics for all three electrolytics have reached the level for measurable intermodulation, which was confirmed by more tests, using 18 Hz as the second frequency.

0.3 volt tests with 0 volt DC bias:-

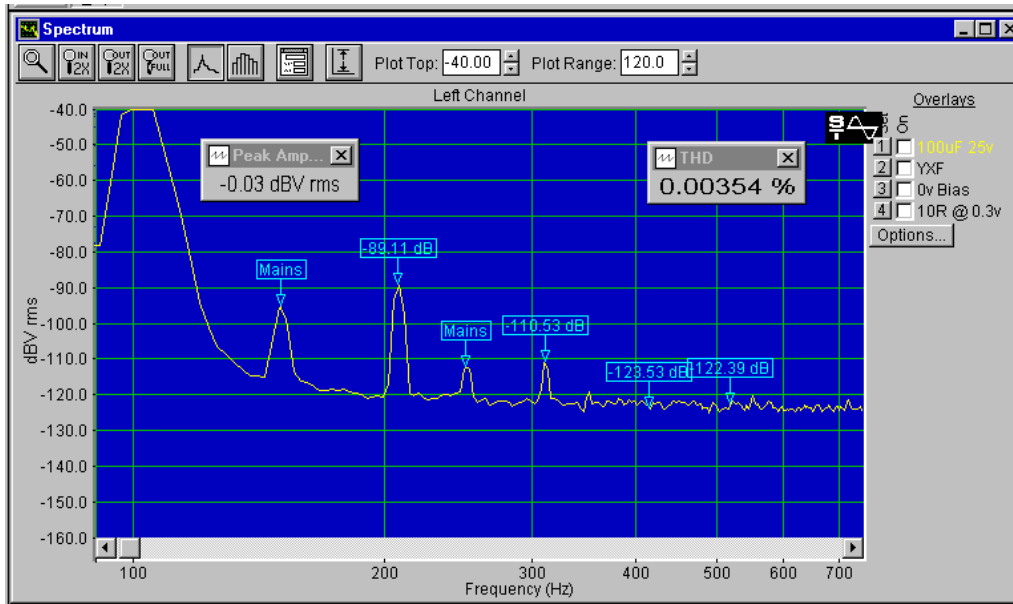

Fig 10A) Measured at 0.3 volts but no DC bias, second harmonic for the YXF at -89.1 dB was some 10 dB larger than for the two specialist capacitors. Distortion has increased to 0.00354%.

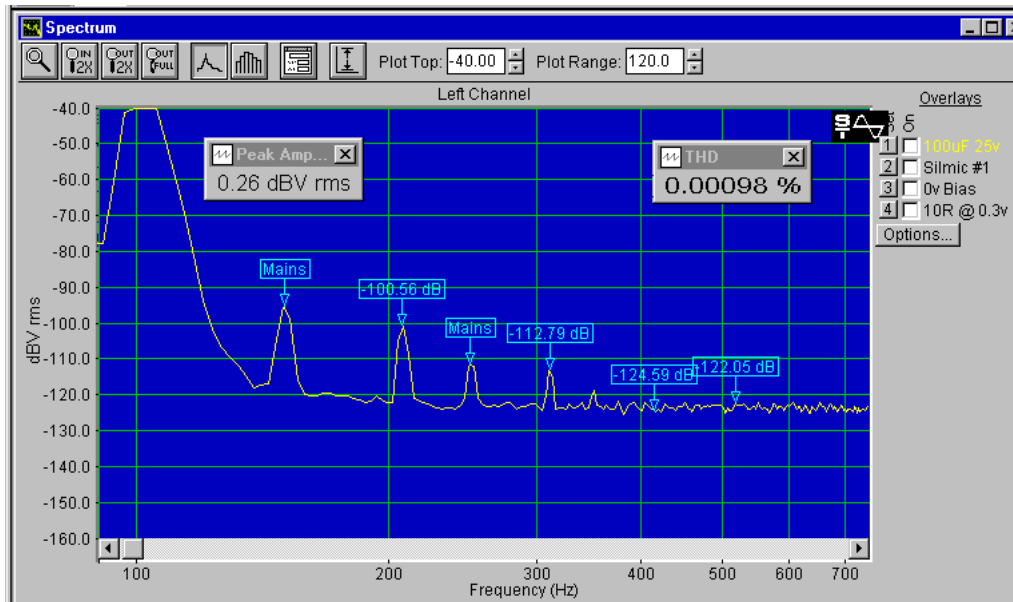

Fig 10B) Measured at 0.3 volts but no DC bias, second harmonic for the Silmic at -89.1 dB was again the best polar capacitor of the three I measured. Distortion has increased to 0.00098%.

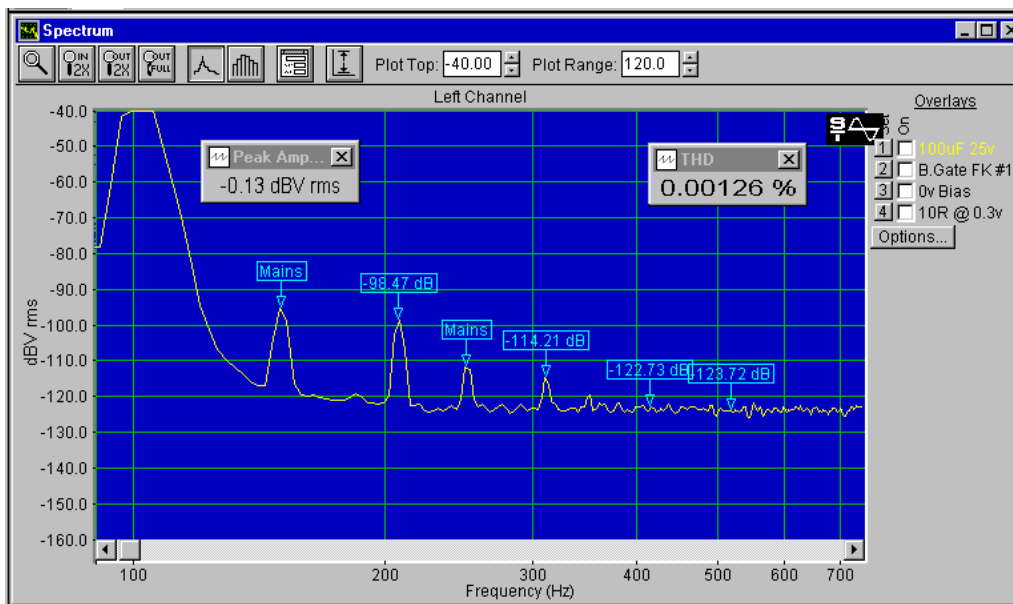

Fig 10C) Measured at 0.3 volts but no DC bias, second harmonic for the Black Gate-FK was some 2 dB worse at -89.1 dB than measured for the Silmic. Distortion now measures 0.00126%.

0.3 volt tests with 6 volt DC bias:-

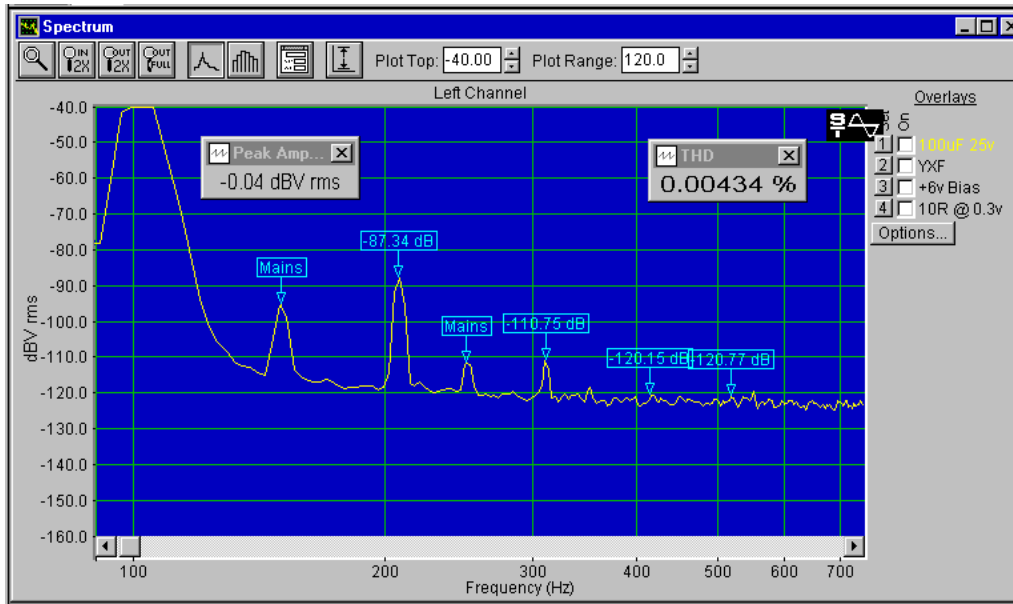

Fig 10D) Measured at 0.3 volts with 6 volt DC bias, second harmonic for the YXF increased by 2 dB to -87.3 dB, third remained at -110.7 dB. Distortion is now 0.00434%.

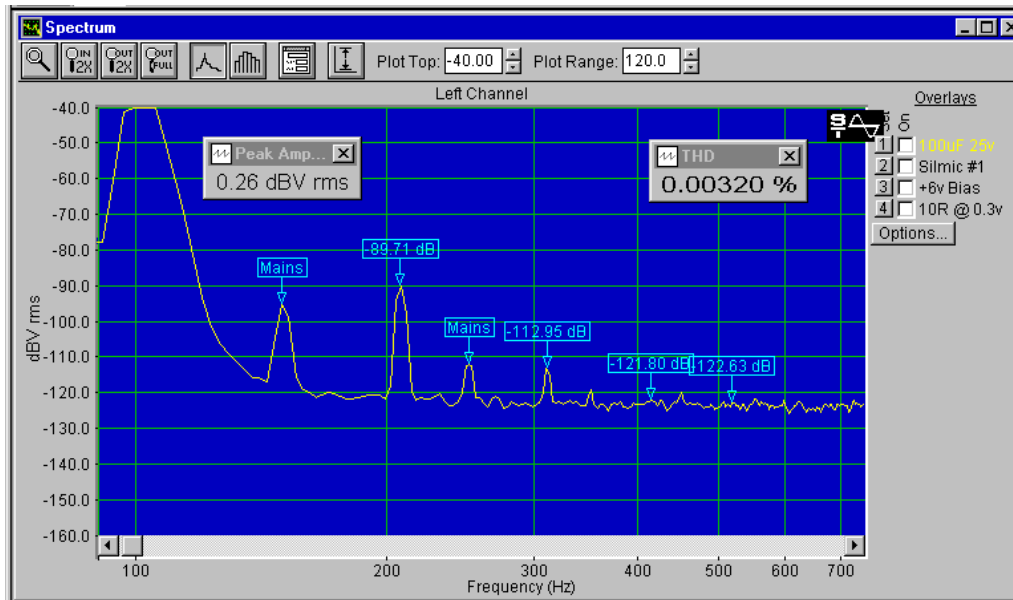

Fig 10E) Measured at 0.3 volts with 6 volt DC bias, second harmonic for the Silmic increased by near 11 dB to -89.71 dB, third was at -112.95 dB. Distortion is now 0.00320%.

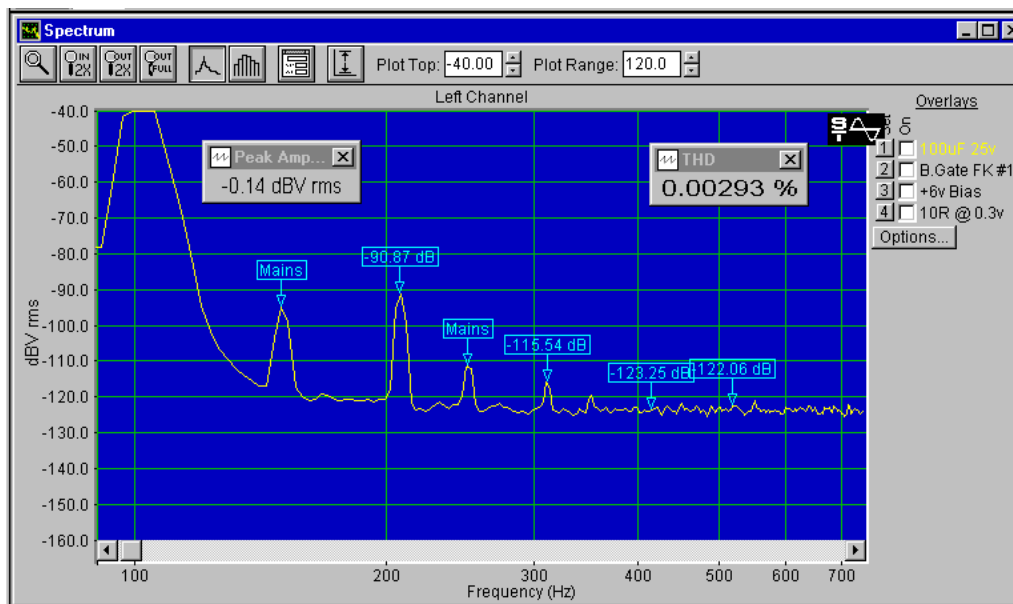

Fig 10F) Measured at 0.3 volts with 6 volt DC bias, second harmonic for the Black Gate-FK increased by near 8 dB to -90.9 dB, third remained at -115.5 dB. Distortion is now best of this three at 0.00293%.

Once more applying just 6 volts DC bias has narrowed the distortion gap between the inexpensive YXF and the expensive Black Gate-FK style.

0.3 volt tests with 18 volt DC bias:-

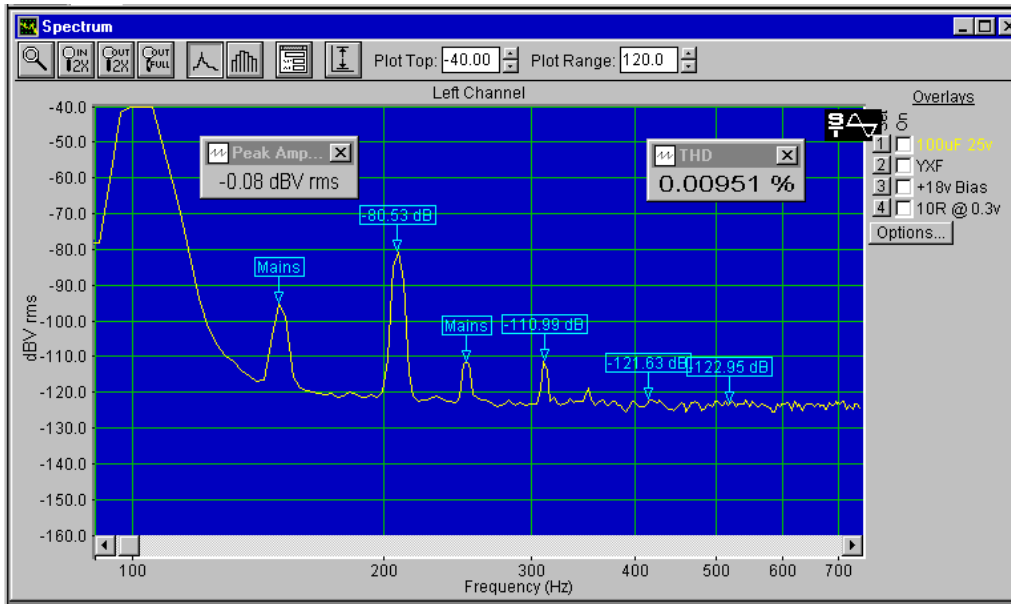

Fig 10G) Measured at 0.3 volts with 18 volt DC bias, second harmonic for the YXF increased by nearly 9 dB to -80.5 dB, third remained unchanged at -110.9 dB. Distortion has increased significantly and is now 0.00951%.

I consider this distortion is far too high for use in the signal path of an audio system.

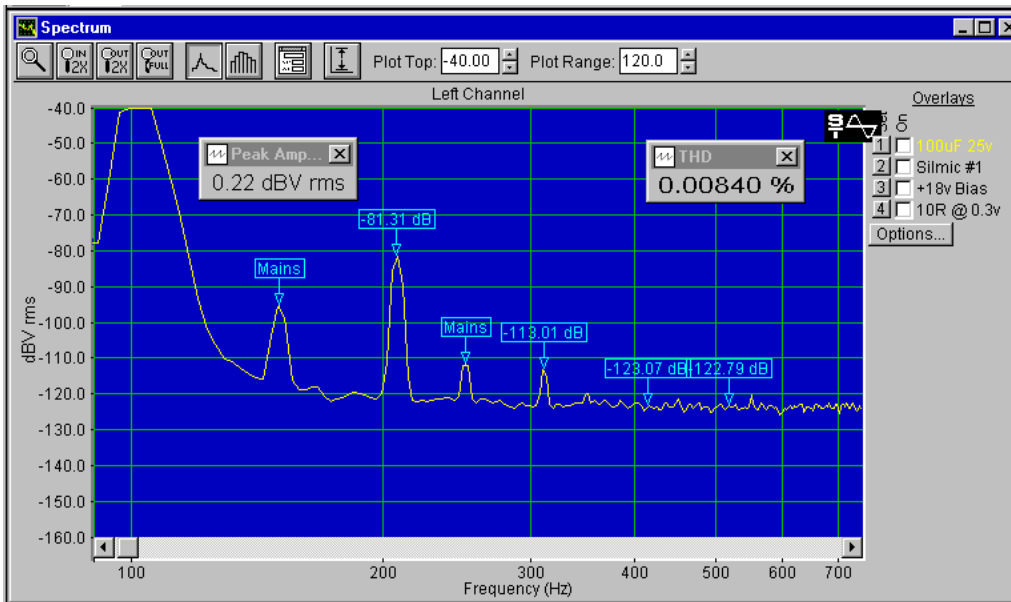

Fig 10H) Measured at 0.3 volts with 18 volt DC bias, second harmonic for the Silmic increased by some 19 dB to -81.3 dB, third continues at -113 dB. Distortion is now 0.00840%.

I consider this distortion is also far too high for use in an audio system.

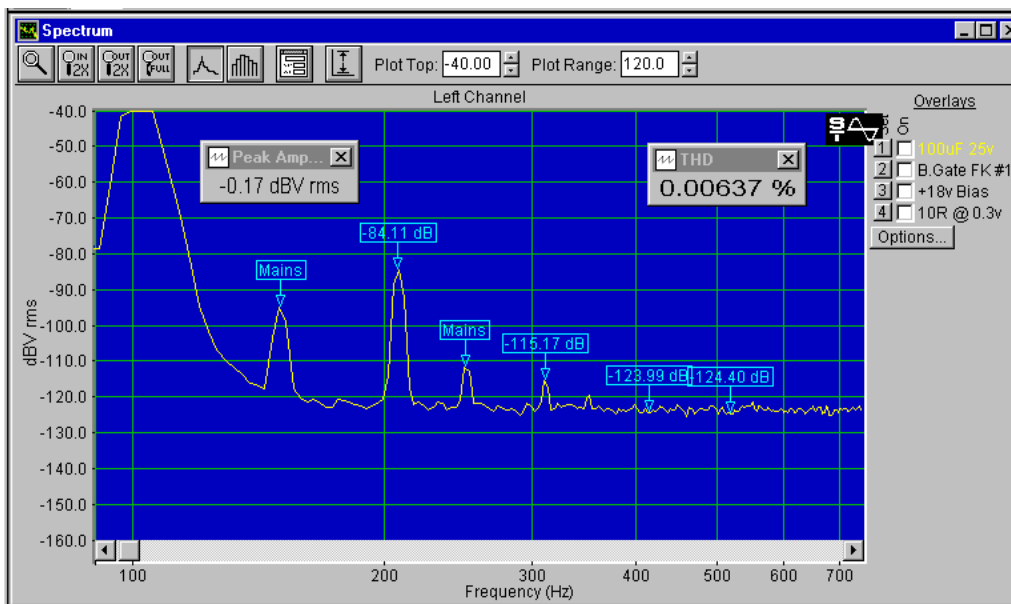

Fig 10I) Measured at 0.3 volts with 18 volt DC bias, second harmonic for the Black Gate-FK increased by some 14 dB to -84.1 dB, third remained at -115.2 dB. Distortion is again best of the three at 0.00637%.

I consider this distortion is far too high for use in an audio system.

Increasing DC bias to 18 volts has had a disastrous effect on distortion for all three types.

All three electrolytics produced significant distortions in these 0.3 volt tests. Almost five times larger with no bias, at least fifteen times larger with bias, than my PET assembly. I consider distortions from these 100 µF polar capacitors tested at 0.3 volts, far exceed the sensible limit for use in the signal path of high quality audio.

Using a Film Shunt.

Some writers advocate using a low distortion film capacitor in parallel with an electrolytic, to reduce distortion. Does it work ? To find out I made a few measurements on these capacitors using a 1 volt test signal, unbiased then with 18 volt DC bias. As shunt I used my low distortion 1 μF MKP also a 10 μF bank of three 3.3 μF low distortion metallised PPS capacitors.

With 1 μF shunt, second and third harmonics of the Silmic reduced by just 1 dB. Using the 10 μF , both harmonics reduced by a further 1 dB. This small reduction is not worth the additional PCB space and extra cost, because even with a 10 μF shunt, distortions far exceed those of my metallised PET assembly.

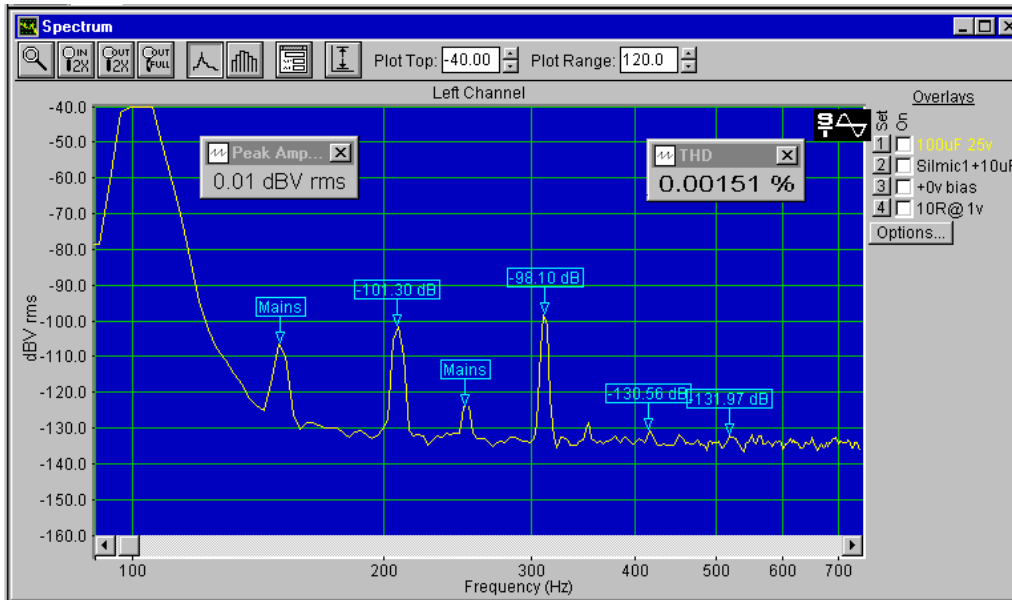

Fig 11A) Re-measured at 1 volt without DC bias but using the 10 μF film capacitor as shunt, we find second harmonic has reduced by only 1.5 dB Distortion was 0.00184% is now 0.00151%.

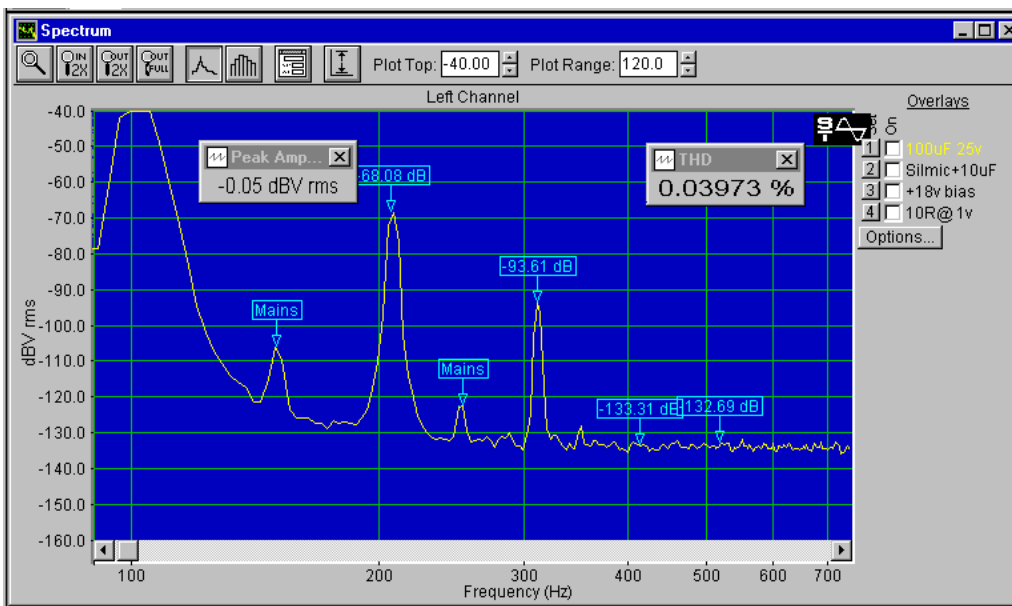

Fig 11B) Measured at 1 volt with 18 volts DC bias and using the 10 μF film capacitor as shunt, we find second harmonic increased to -68 dB. Distortion is 0.03973% .

I consider these distortions are far too high for use in the signal path of an audio system.

Perhaps a higher voltage capacitor would measure better, or would its much larger area anode and cathode foils simply make matters worse ?

100 μF 50 volt tests.

Examination of my earlier distortion plots suggested the only suitable 100 μF electrolytic types I had which might measure lower distortion were the 22 \times 12.5 mm 50 volt Silmic and the 26 \times 12.5 mm 50 volt Panasonic S Bi-polar, Farnell 218-698.

With 0.3 volt test signal and no bias, the 50 volt Silmic distorted more than the 25 volt version. Because of its much longer and wider foils, second harmonic increased 2 dB, third increased 7 dB and distortion measured 0.00134%. see **Fig.12A**

Due to the thicker dielectric used for the 50 volt capacitor, with 18 volt DC bias, second harmonic increased less, now almost 6 dB smaller than the 25 volt version. Distortion at 0.00460% was just over half that of the 25 volt version.

Comparison tests, 100 μF 25 volt and 50 volt rated 'Silmic' capacitors.

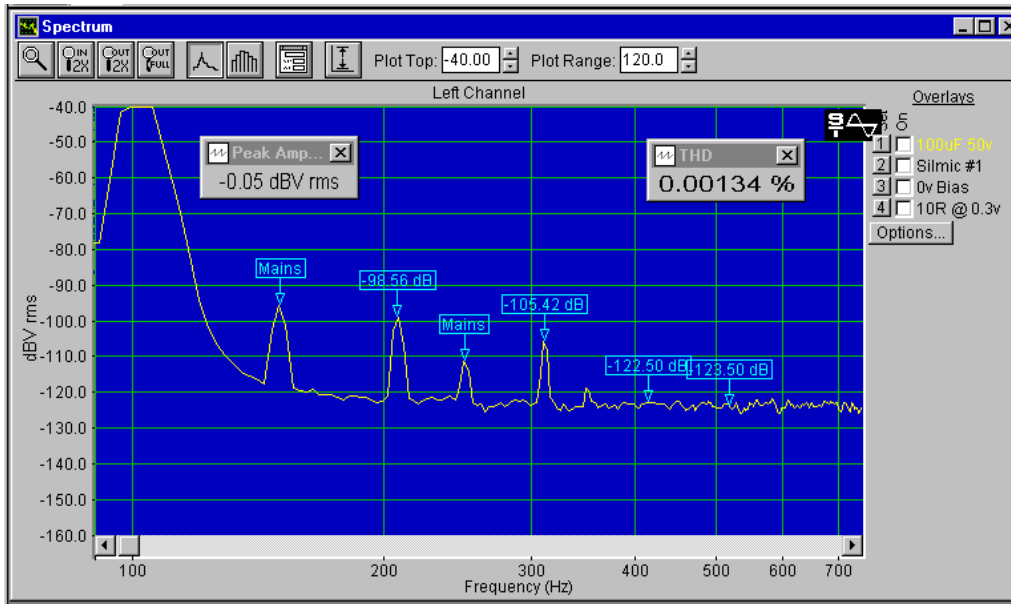

Fig 12A) Measured with no DC bias at 0.3 volt, we find second harmonic has increased by 2 dB and third harmonic by 7 dB when compared with the 25 volt capacitor. Distortion has increased to 0.00134% for 50 volt capacitor, from 0.00098% for the 25 volt version.

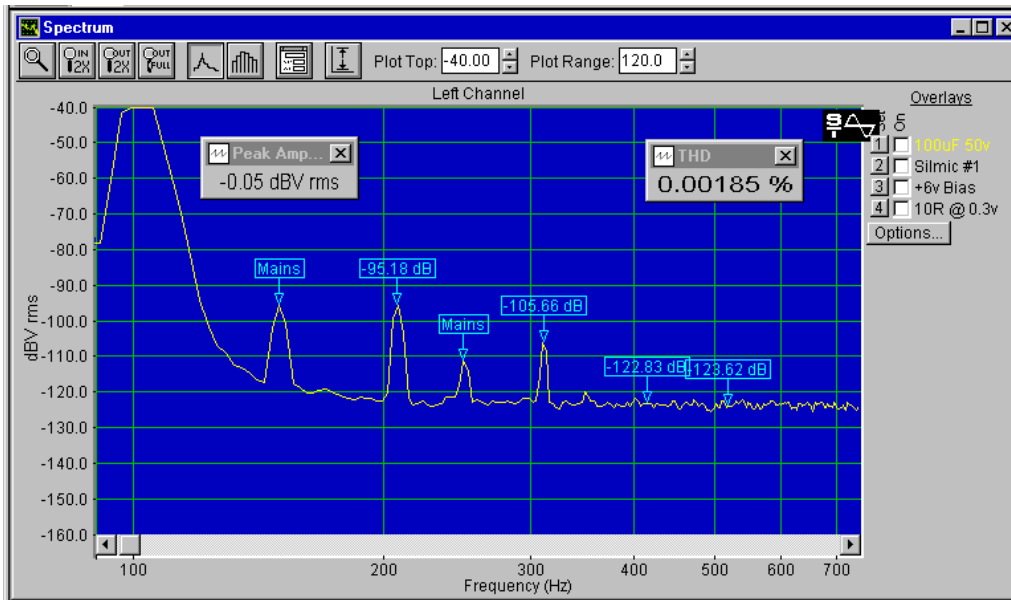

Fig 12B) Measured with 6 volt bias at 0.3 volt, we find second harmonic has increased by another 3.5 dB but third harmonic at -105.6 dB has not changed. Distortion now 0.00185%.

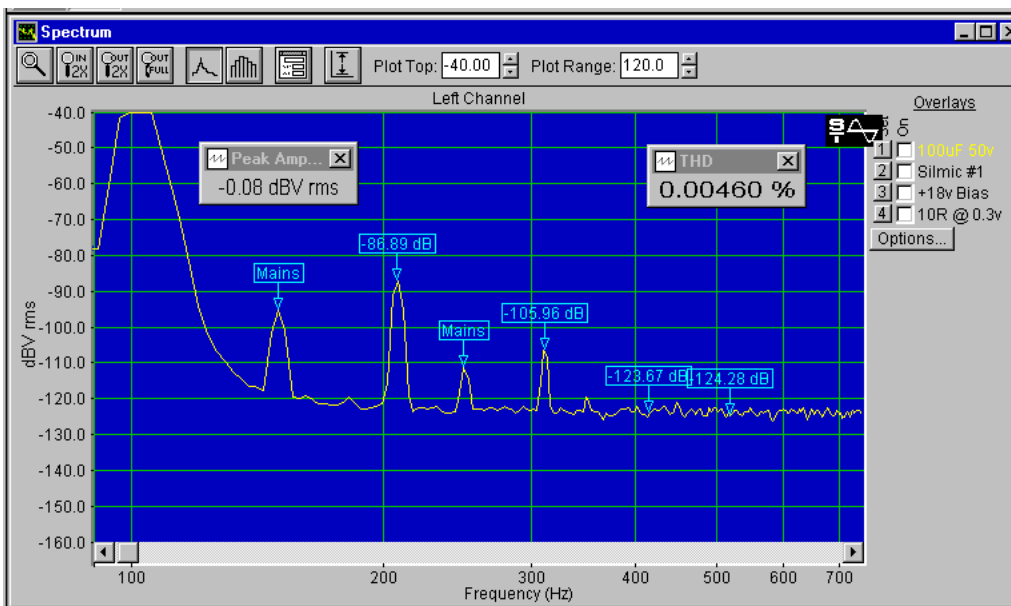

Fig 12C) Measured with 18 volt bias at 0.3 volt, we find second harmonic has increased by almost 12 dB, third harmonic at -105.9 dB unchanged. Distortion now 0.00460%.

Comparison tests, 100 μF 'Silmic' polar and 50 volt rated Panasonic Bi-polar capacitors.

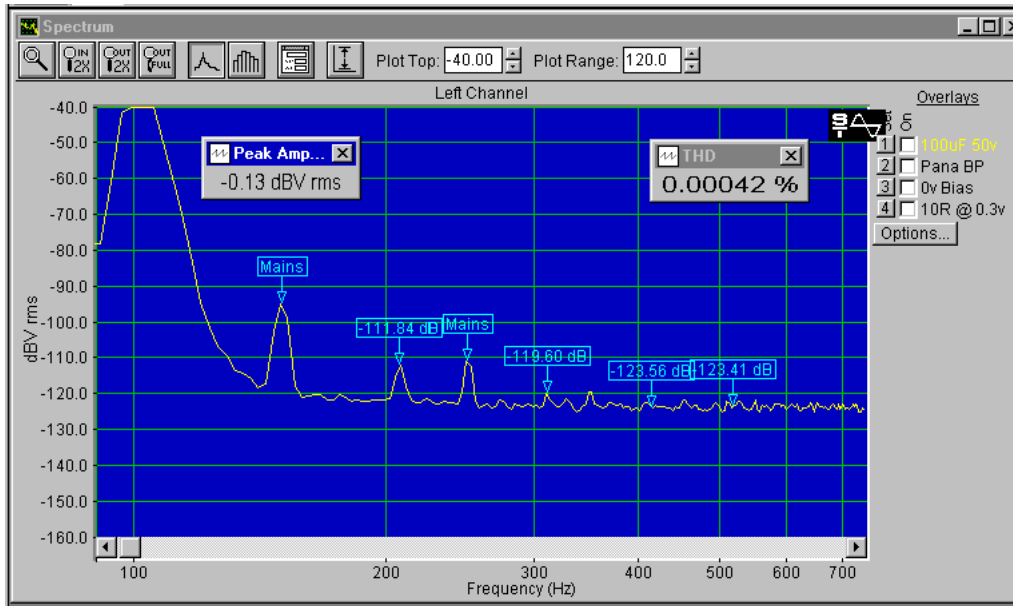

Fig 12D) Measured with no DC bias at 0.3 volt, we find second harmonic for this Panasonic Bi-polar reduced by nearly 12 dB. Third harmonic is now near the measurement noise floor at -119.6 dB.

Distortion is the lowest seen so far for an electrolytic and less than half that of the 25 volt Silmic.

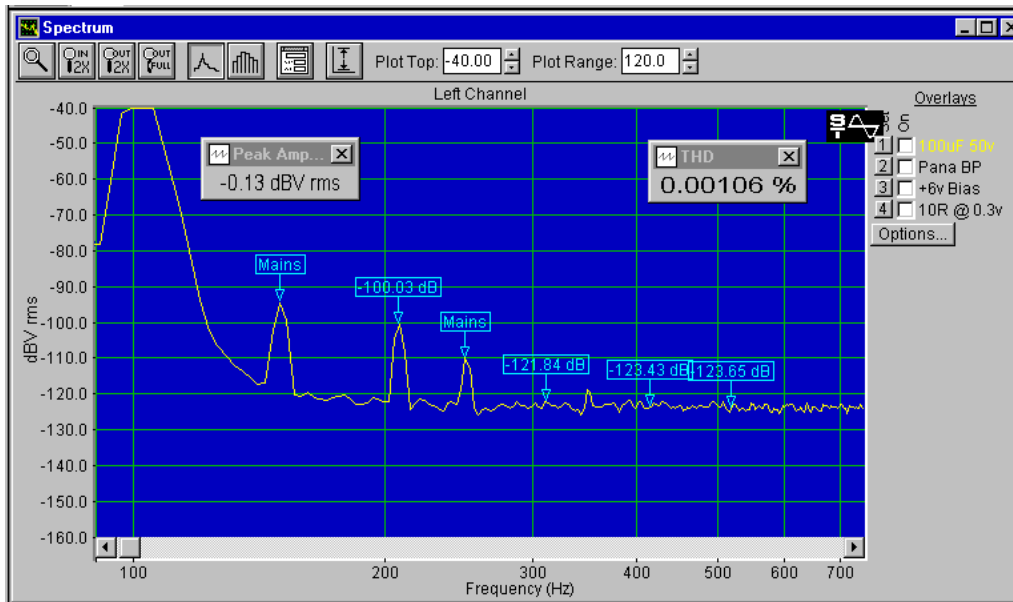

Fig 12E) Measured with 6 volt DC bias and 0.3 volt, we find second harmonic almost identical to that measured on the Silmic with no bias, 10 dB smaller than for the 25 volt Silmic with 6 volt bias.

Third harmonic remains near the measurement noise floor.

Distortion is now 0.00106%.

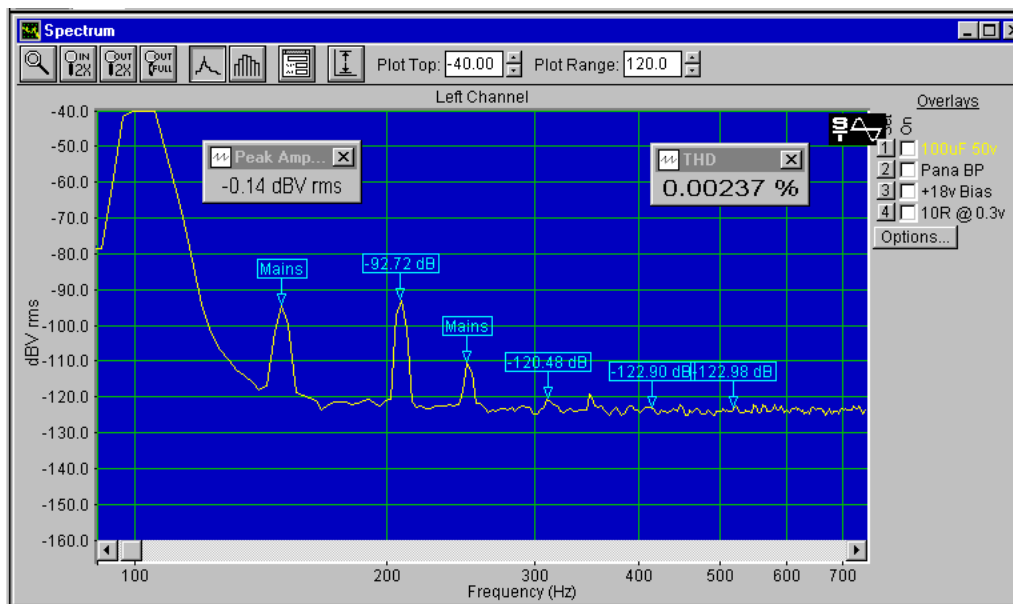

Fig 12F) Measured with 18 volt DC bias at 0.3 volt, while distortion has increased it is less than half that measured on the best polar capacitor tested.

Third harmonic remains near the measurement noise floor at -119.6 dB.

Distortion is now the lowest seen so far for an electrolytic with 18 volt bias, half that of the best polar type measured with 18 volt DC bias.

Bi-polar.

The Panasonic S Bi-polar capacitor at 0.3 volt with no bias, produced less than half the distortion of the 25 volt Silmic. Second harmonic measured -111.8 dB, third -119.6 dB and distortion 0.00042%.

With 18 volt DC bias, second harmonic increased to -92.7 dB and distortion to 0.00237%, half the distortion of the 50 volt Silmic.

The Panasonic S Bi-polar produced the lowest distortion of all single 100 μF electrolytic capacitors of those I tested, using a 0.3 volt signal and DC bias from 0 volt to 18 volts. see **Fig.12 D/F**

In my last article we saw how using two polar capacitors in series could reduce distortion. Let us now explore using two Bi-polar capacitors in series.

Two better than one?

I already had some 220 μF 63 volt Nitai Bi-polar electrolytics, Farnell 317-4906. Two connected together in series would approximate 100 μF .

Measured at 0.3 volts with no bias, second harmonic level reduced 6 dB compared to the Panasonic S Bi-polar. With second and third harmonics buried in the noise floor, distortion at 0.00033% measured the same as the PET assembly.

With 18 volt DC bias, second harmonic measured -105.3 dB and distortion 0.00063%. A near four fold improvement compared to the Panasonic S Bi-polar, more than seven times better than the best polar capacitor tested.

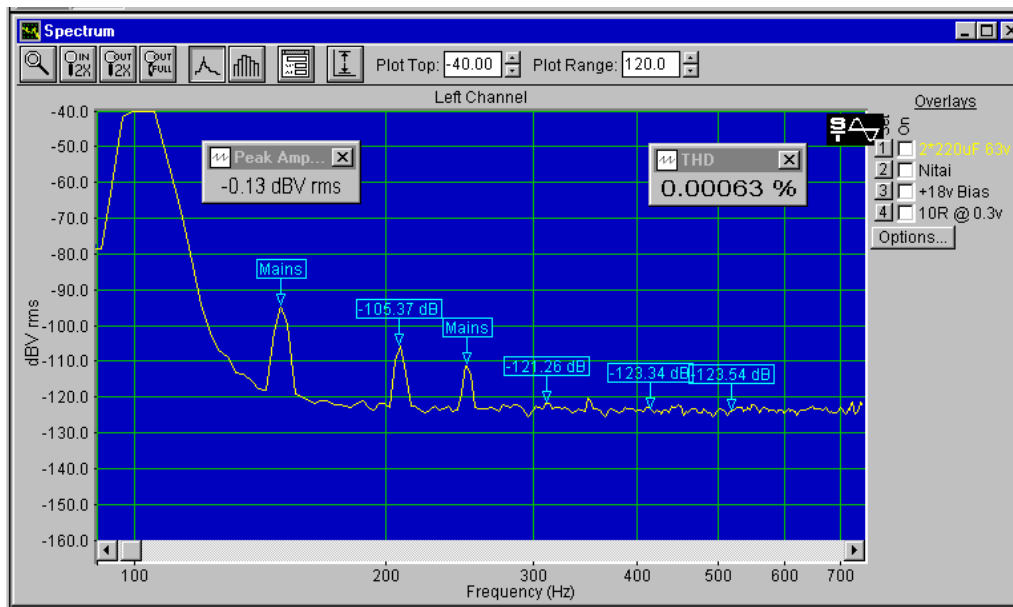

Fig 13) Series pair of 220 μF 63 volt Nitai Bi-polar electrolytics, measured with 18 volt DC bias at 0.3 volt, second harmonic distortion has reduced dramatically. It is now seven times smaller than measured on the best polar capacitor tested.

Third harmonic remains on the measurement noise floor.

To better compare harmonics I examined performances using a 0.5 volt signal. With no bias, those for my PET assembly can just be seen emerging from noise. Second harmonic -124.3 dB, third -123.9 dB and distortion 0.00020%. see **Fig 7**

The double 220 μF 63 volt Bi-polar second harmonic -117.7 dB, third -124.1 dB, and distortion 0.00023%, measured practically the same distortion as the PET assembly. see **Fig.14A**

With 18 volt DC bias, second harmonic of the double Bi-polar increased to -100.7 dB and distortion to 0.00093%, slightly more than double the distortion measured on the PET assembly with this bias. see **Fig.14C**

This is an excellent performance from a pair of inexpensive electrolytic capacitors, but how does this series pair of Bi-polar capacitors stack up for size and cost ? Can this Bi-polar series pair still produce low distortion tested with a 1 volt signal ?

At 1 volt with no bias, noise floor improved to -132 dB. Distortion of the PET assembly measured 0.00011%, a single Panasonic S Bi-polar 0.00054% and the Silmic 25v with 10 μF shunt 0.00151%.

The 220 μF 63 volt Nitai series pair measured 0.00016%, practically equalling that measured on the PET assembly, and ten times less distortion than the Silmic 25 volt polar capacitor.

With 18 volt DC bias, the 220 μF 63 volt Nitai series pair distortion measured 0.00217%.

Double Bi-polar series connected pair of 220 μF 63 volt Nitai capacitors tested at 0.5 volts.

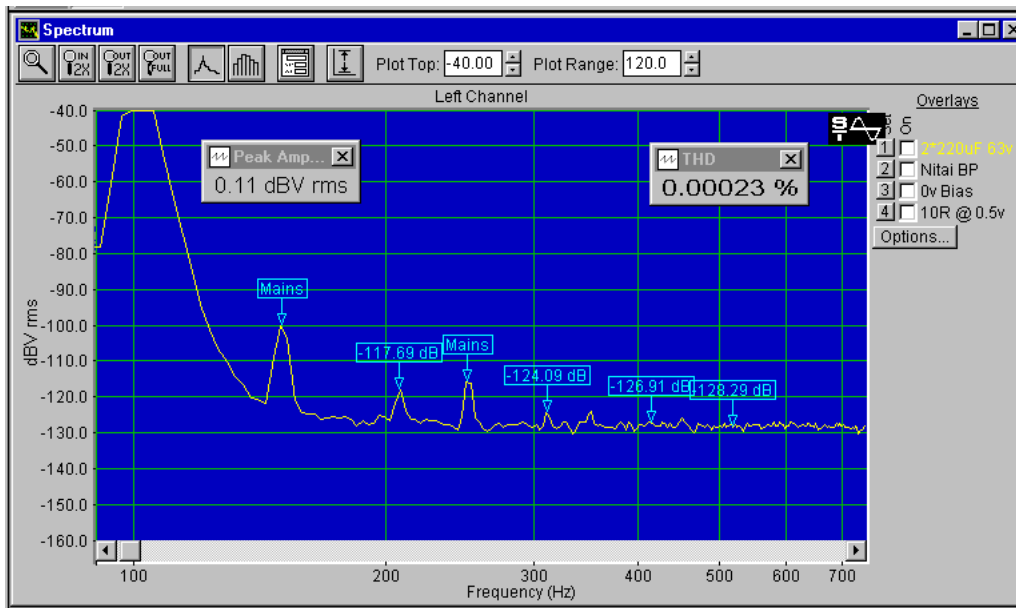

Fig 14A) Series pair of 220 μF 63 volt Nitai Bipolar electrolytics, measured with no DC bias at 0.5 volt. Second harmonic distortion now -117.7 dB, third harmonic remains near the measurement noise floor.

Distortion measures 0.00023%, practically the same distortion as measured using my PET assembly.

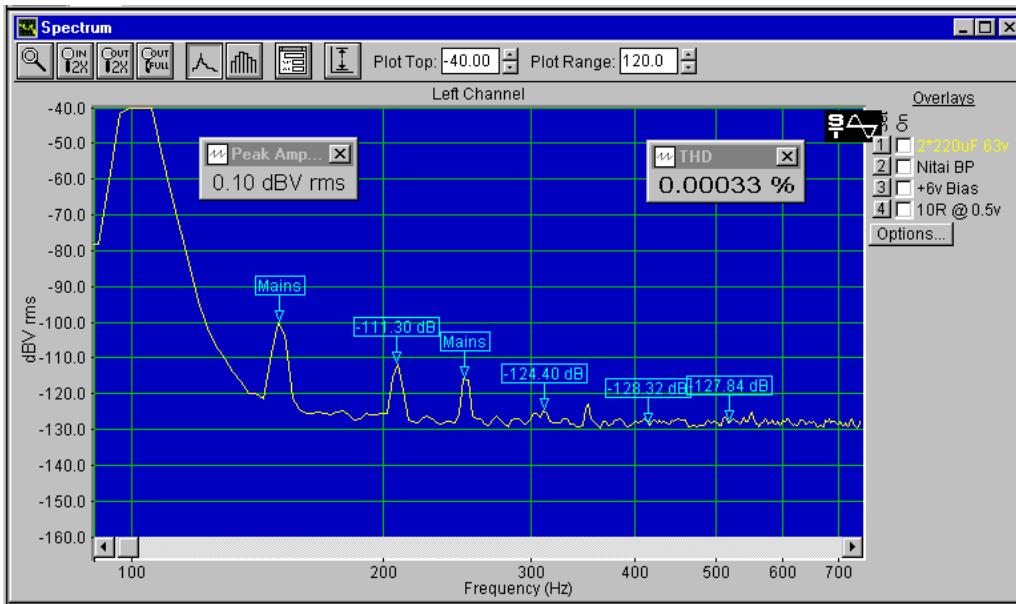

Fig 14B) Measured at 0.5 volt with 6 volt DC bias. Second harmonic distortion now -111.3 dB, third harmonic remains near the measurement noise floor.

Distortion now measures 0.00033%.

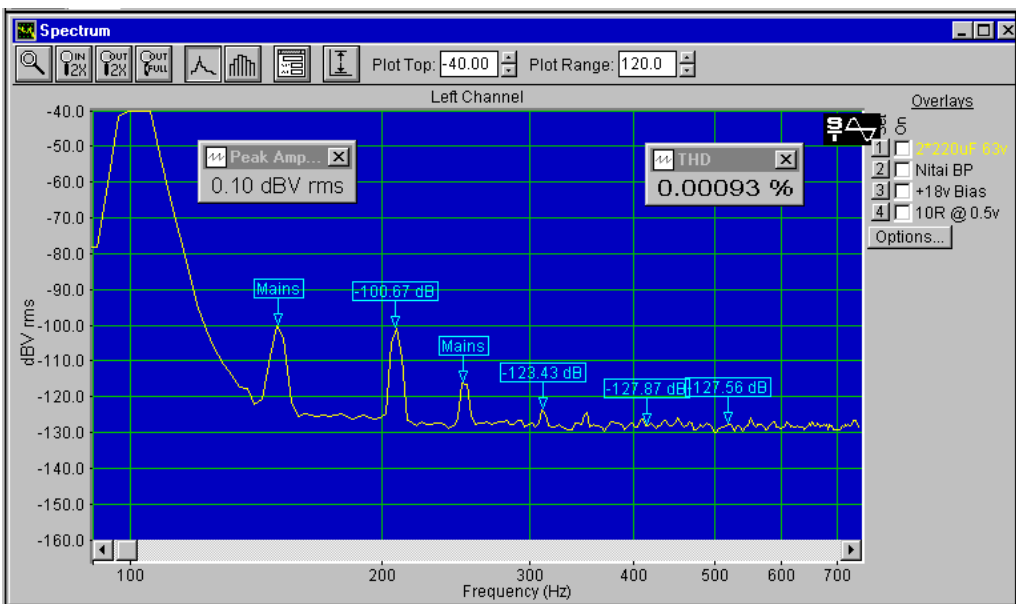

Fig 14C) Measured at 0.5 volt with 18 volt DC bias. Second harmonic increased to -100.7 dB. Third harmonic remains near the measurement noise floor.

Distortion is 0.00093%, little more than double that measured for my PET assembly.

At this voltage the Silmic measured 0.01312% the Black Gate-FK was 0.01041%.

Double Bi-polar v alternatives.

The series pair requires less PCB area, is lower cost and dramatically outperforms a polar capacitor with film shunt.

At 1 volt with no bias, noise floor improved to -132 dB. Distortion of the PET assembly measured 0.00011%, a single Panasonic S Bi-polar 0.00054% and the Silmic 25volt with 10 μ F shunt 0.00151%.

The 220 μ F 63 volt Nitai series pair measured 0.00016%, practically equalling that measured on the PET assembly, ten times less distortion than the Silmic 25 volt capacitor.

With 18 volt DC bias, the 220 μ F 63 volt Nitai series pair distortion measured 0.00217%. Slightly more than six times that of the PET assembly but nearly seven times less distortion than using the 50 volt Silmic polar capacitor.

This series pair of 220 μ F 63 volt Nitai Bi-polar capacitors costs one eighth and takes just one fifth the PCB area of my PET assembly.

To explore other double Bi-polar options, I purchased 35 volt and 16 volt 220 μ F Nitai Bi-polar capacitors for tests.

Smaller Doubled Bi-polar.

With no bias and tested at 0.5 volt, distortion for all three voltage Bi-polar doubles, measured almost the same as the PET assembly, but 18 volt DC bias revealed large differences. The 16 volt series pair measured 0.00693%, the 35 volt series pair 0.00230% and the 63 volt series pair 0.00093%.

For the lowest possible distortion when DC blocking/signal coupling, I suggest the 16 volt pair is only used with negligible DC bias, the 35 volt pair be used to say 6 volt bias and the 63 volt pair to say 12 - 15 volts bias. With such small DC voltages, no voltage sharing resistors are needed.

Used in a 'Long Tailed Pair' amplifier feedback network to ensure unity gain at DC, the 63 volt series pair could be used with supply rails up to 63 volts, without voltage sharing resistors. For higher voltages use a series pair of 100 volt Bi-polar.

This 63 volt series pair can also benefit local supply rail decoupling, but for this use, voltage sharing resistors, passing a few mA from the supply to the capacitors central connection and ground, must be used.

Conclusions.

Having measured a considerable number of aluminium electrolytics using test voltages from 0.1 volt to 3 volt, with and without bias, a single Bi-polar type produced lower distortion than larger, more expensive, specialist polar capacitors..

Much better results were obtained by connecting two double capacitance value Bi-polar electrolytics in series. Using 1 volt or smaller test voltages and no bias, distortions for a double Bi-polar and the metallised PET assembly were similar.

With increasing bias or with increasing test voltage, the metallised PET assembly produced less distortion than any electrolytic I tested.

Distortion with voltage.

We have seen how the test voltage used influences various capacitors. With sufficient test signal, most film and all electrolytic capacitors will distort. It is prudent in any audio design to minimise the level of AC signals which are developed across any capacitor.

At low frequencies this becomes difficult and may force a trade off between capacitor size and distortion. Equally important is the level of DC bias voltage the capacitor must sustain. If more than a few volts, then for low distortion a low dielectric absorption material is essential.

Because distortion results from non-linearities inside the capacitor, inevitably it increases disproportionately both with capacitance value and applied voltage.

The change in amplitude of second harmonic, when tested at a constant signal with and without DC bias, clearly results from the DC bias voltage used, dielectric absorption and dielectric thickness.

Regardless of capacitance value, to minimise second and third harmonic distortions with increased AC and DC voltages, such as found in valve amplifiers, then a foil and Polystyrene, foil and Polypropylene or double metallised foil, two-series, MKP Polypropylene capacitor, should be used.

100 μ F choice.

Provided the AC voltage developed across the capacitor at the lowest audio frequencies is 1 volt or less and no significant DC bias is used, a double Bi-polar series pair provides an economic solution.

When higher AC signal voltages, especially combined with significant DC bias, must be applied, the metallised PET combination produces less distortion. It costs eight times more and takes five times more PCB area than the double Bi-polar.

For the least practical distortion, an assembly of metallised Polyphenylene Sulphide capacitors might be feasible. It needs double the board area and is five times more expensive than the PET assembly.

For small AC signals with modest DC bias and for supply rail decoupling, I choose the double Bi-polar 63 volt solution.

10 μ F choice.

We have three possibilities. A double Bi-polar using two 22 μ F 50/63 volt Bi-polar electrolytics, a 10 μ F metallised PET or an assembly of three 3.3 μ F PPS capacitors.

The lowest cost solution for use with signal voltages less than 1 volt and no significant bias, is a double Bi-polar series pair.

A 10 μ F MMK metallised PET takes the same PCB area and distorts less with DC bias.

The PPS capacitor assembly ensures lower distortion, especially when used with increased AC signals or DC bias voltage. However it occupies more board area and is expensive.

An assembly of Polypropylene capacitors, as used in the DC bias network, would provide the lowest possible distortion but requires a five times larger board area and is most expensive.

For small AC signals and modest DC bias, I choose the 10 μ F MMK metallised PET capacitor.

END**References.**

- | | |
|---|---------------------------------------|
| 1) Capacitor Sound part 5 C.Bateman | Electronics World December 2002 p.44 |
| 2) Capacitor Sound ? C.Bateman | Electronics World July 2002 p.12 |
| 3) Capacitor Sound 2 C.Bateman | Electronics World September 2002 p.16 |
| 4) Understanding capacitors - Aluminium and tantalum
C.Bateman | Electronics World June 1998 p.495. |
| 5) Evaluate capacitors for SMPS designs.
C.Bateman | Electronics World Sept 2000 p.696 |
| 6) Reference Data for Radio Engineers. | Howard Sams & Co. Inc. New York |