

## THE DEVELOPMENT AND THEORY OF MAGNETIC TAPE RECORDING

There is no definite beginning to the history of magnetic recording but we can be certain that credit for building the first magnetic recorder belongs to Valdemar Poulsen. This Danish telephone engineer who is often referred to as the "Father of Magnetic Recording" designed the microphonograph which was an invention of great scientific significance. In this apparatus a steel wire was moved with considerable velocity between the poles of a small electromagnet. By using this device a conversation could be permanently recorded for reproduction at any time.

In the early 1900's many scientists were attempting to use magnetic tape in preference to the earlier idea of wire. About 1927 a German inventor named P. Fleumer was experimenting with powdered coatings on tape. So far as we know he did not use magnetic oxide but coated his tapes with powdered metallic materials. Development continued and finally about the year 1939 the Germans produced a tape using a durable plastic backing. This began a new era in the improvement of magnetic tapes, culminating in the superior fidelity we all know.

*Valdemar Poulsen*



To understand completely the uses and operating techniques of your Ampex Series 300 Tape Transport, the basic theory of Magnetic Tape Recording should be emphasized at this time . . .

## THEORY OF MAGNETIC TAPE RECORDING

If a material capable of being magnetized is placed in the proximity of a magnetic field the molecules of that material will be oriented according to the direction of the field. Any of several methods may be used to produce a magnetic field, but of most interest in magnetic recording is the field produced by a current flowing through a coil of wire. The current itself may be derived from a transducer such as a microphone which converts the mechanical energy of sound to electric current.

Magnetic recording tape consists of finely divided iron-oxide particles deposited upon a plastic backing. During the recording process this tape is moved through a magnetic field in which the magnetizing force is alternating, and the iron oxide particles are aligned according to the instantaneous direction and magnitude of the field.

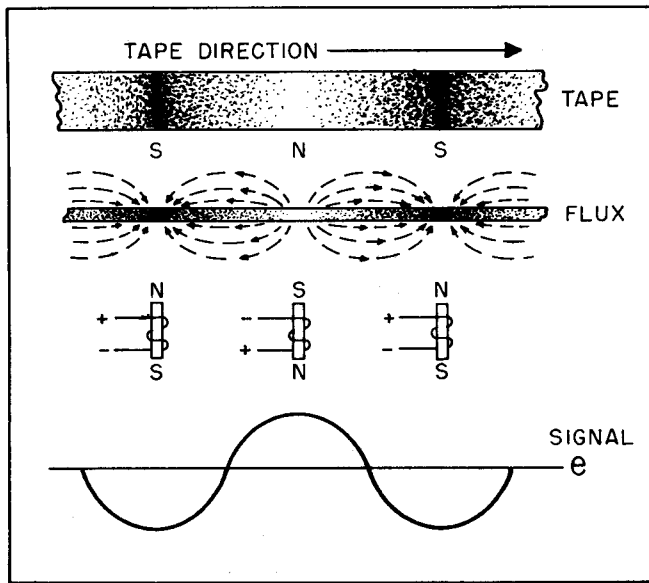

*Magnetization of Tape*

The magnetic field is produced in the gap of a recording head (which is essentially an electro-magnet) over which the recording tape passes. The head consists of an incomplete ring of highly permeable material inserted in a coil of wire. The discontinuity in the ring forms the gap, and the ring itself is the core of the electromagnet. The recording head and its gap thus constitute a series magnetic circuit.

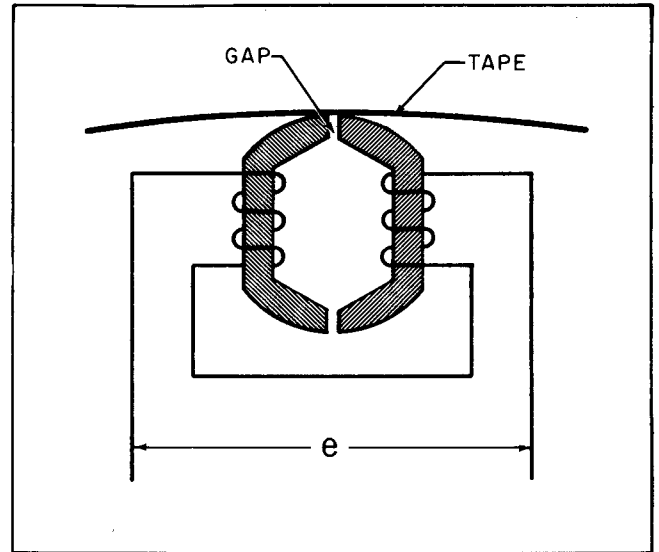

*Record Head*

The magnetization curve of the iron oxide used as the recording medium is similar to that shown as the heavy line in the illustration above.

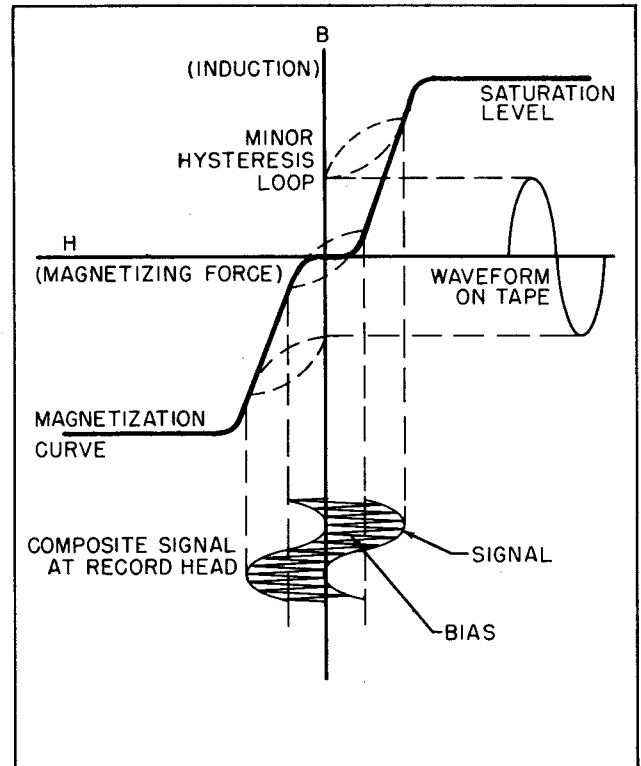

*Recording medium magnetization curve*

At points near the origin the curve is extremely non-linear and, without some corrective factor, the signal recorded on the tape would not be directly proportional to the signal applied to the head, resulting in a high degree of distortion when the tape was reproduced. This distortion is greatly reduced by mixing a high frequency, constant amplitude, bias signal with the actual signal being recorded, so that operation is obtained on the linear portion of the curve. This may be likened to applying a d-c bias to a tube to force it to work on the linear portion of its curve. The bias signal is generally selected to be at least five times the highest frequency to be recorded so that no beating will occur between the bias frequency and the harmonics of the recorded signal.

While the tape is in the recording gap the bias causes the magnetization characteristics of the iron oxide to follow the dashed line loops known as the "minor hysteresis loops." As the tape leaves the gap the influence of the magnetic field created by the bias is reduced to zero and the tape assumes a permanent state of magnetization (known as "remanent induction") determined by the gap influx at that time.

After the recording process there exists on the tape a flux pattern which is proportional in magnitude and direction to the signal recorded. If the tape is then moved past a reproduce head—which is similar in construction to the record head—the magnetic flux on the moving tape will induce a voltage in the coil of the reproduce head. This induced voltage is proportional to the number of turns of wire on the head and the rate of change of flux. This is expressed by the equation  $E=N(d\phi/dt)$

Where

$E$ =induced voltage

$N$ =number of turns of wire

$d\phi/dt$ =rate of change of flux

It is desirable that the gap in the reproduce head be as small as possible so it will intercept less than one wave length of the signal on the tape at the highest frequency to be reproduced. However, as the gap is made smaller the induced voltage decreases, so there is a practical limitation in decreasing the gap and still maintaining an adequate signal-to-noise ratio.

The voltage induced in the reproduce head during reproduction is computed by the equation  $E=B_M V \text{SIN} \pi \omega / \lambda$

Where

$E$ =induced voltage

$B_M$ =maximum flux density of the recording material

$V$ =velocity of tape over the head

$\omega$ =width of the gap

$\lambda$ =wavelength of the signal on the tape

From this equation it can be seen that the voltage across the coil increases directly as the velocity increases and as the wavelength decreases (frequency increases). If the tape velocity and gap width are assumed to be constant, the output voltage from the head is directly proportional to the frequency as long as the wavelength on the tape is large compared to the gap width. This results in an output vs. frequency characteristic such as is shown in curve A of the figure below.

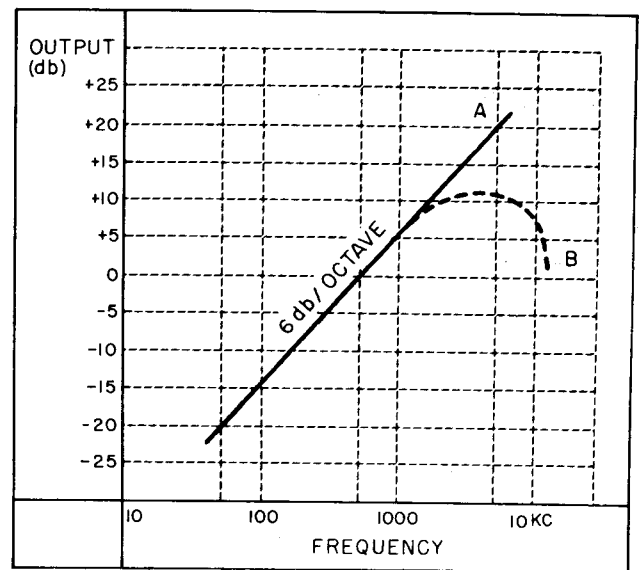

*Reproduce head characteristics*

The voltage does not continue to rise indefinitely. As electrical losses in the core material increase and as the wavelength on the tape approaches the same dimensions as the reproduce head gap, the actual output resembles curve B in the same figure.

In order to provide an over-all frequency response that is flat (see the figure below) an equalization circuit consisting of a series resistance and capacitance is inserted in one of the early stages of the reproduce amplifier. This equalizing circuit has a high-frequency droop characteristic (curve B) which is the inverse of

the reproduce head characteristic curve A of above figure. In order to extend the high frequency response, additional equalization is included in the record amplifier in the form of a high frequency boost circuit designed to compensate for the droop in record and reproduce head characteristics caused by core losses, self-demagnetization of the tape at the short wave lengths and the wave length approaching the gap dimensions.

Disregarding the response of the associated amplifiers, the physical aspects of maintaining constant tape speed and good head-to-tape contact, and core losses in the head—all of which can be placed at a high performance level by good engineering design—there are certain inherent properties which define the frequency limits in recording and reproducing information on a specific magnetic tape recorder-reproducer. While these properties can be varied to meet differing requirements, the over-all result represents a compromise arrangement in which frequency response, signal-to-noise, and distortion are interrelated.

In this respect the high frequency response is primarily limited by the dimension of the reproduce head gap, and the frequency at which the head resonates with the capacity in the circuit.

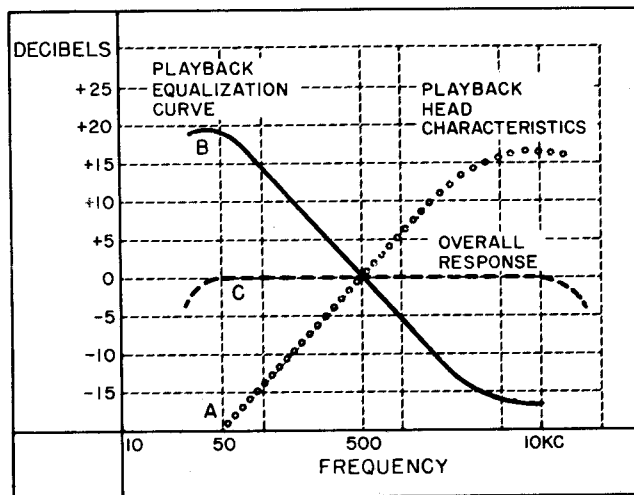

*Achieving flat overall response*

During the recording process the tape assumes a permanent state of magnetization as it leaves the head gap, thus the record head gap width is relatively uncritical. However,

in the reproduce mode the magnetic flux on the moving tape must induce a voltage differential across the reproduce head coil if a current is to flow in that coil. This induced voltage is attained as the flux travels through each branch of the head core, forced into that path by the high reluctance of the head gap. Therefore, an instantaneous difference in the magnitude of the moving flux must exist across the head gap to cause the flux to travel through the core and magnetically induce a voltage difference in the head winding.

When the recorded frequency rises to a degree where the reproduce head gap intercepts a complete wavelength of the signal (as it appears on the tape) there can be no difference in flux magnitude across the gap, and head output will reduce to zero. This cancellation effect will occur at multiples of the represented frequency, and for all practicable purposes the output is useless.

There are two means of counter-acting this "gap effect"—either the reproduce head gap width can be reduced or the record-reproduce tape speed can be increased. There are limitations in reducing the gap width and retaining adequate signal level and realistic manufacturing tolerances; as these limitations are reached any further extension of high frequency requirements must be accompanied by corresponding increases in record-reproduce tape speed. (In instrumentation applications it is also possible to record at a high tape speed and reproduce at a low tape speed, thus providing a signal expansion characteristic. For example, a 10 kc signal recorded at 7½ ips, will reproduce as a 5 kc signal if the reproduce tape speed is 3¾ ips. This procedure of course cannot be used in standard audio applications where music or voice is recorded, and will result in the loss of the low frequency components of the signal.) Increasing the record-reproduce tape speed lengthens the wavelength of the signal as it appears on the tape, with the result that higher frequency wavelengths do not approach the gap dimension. (It also decreases the "self-demagnetizing" effect which occurs as the opposite poles of individual magnetic fields on the tape come closer and closer together.)

The resonant frequency of the inductance of the head coil and the capacitance—either actual or distributed—of its circuit must normally be

either outside the pass band of the system (so the drop in output following the point of resonance will not adversely effect the frequency response) or so placed at the extreme upper limit so that the increased output at the moment of resonance actually provides an extended response. When good engineering design has reduced circuit capacitance to an irreducible minimum, the only means of placing head resonance at a higher frequency is to reduce the inductance of the head coil by reducing the number of turns of wire. This adversely affects the output over the entire frequency range, and will particularly influence the low frequency limit.

Low frequency response is primarily determined by the relationship of the required signal-to-noise ratio, the characteristic curve of the reproduce head, the distortion which can be tolerated, and the bandwidth which must be recorded.

As previously explained the output of a reproduce head rises directly with frequency at an approximate 6 db per octave rate. Stated conversely, the reproduce head output drops directly with frequency at an approximate 6 db per octave rate. The low frequency limit is determined by how far this decreasing output can be tolerated while maintaining an adequate

signal-to-noise ratio. Thus, the noise generated by the associated electronic assemblies will have a definite effect on low frequency response. Increasing the record level to offset this decreasing output will eventually result in an increase in distortion.

Bandwidth is a determining factor in low frequency response because the 6 db per octave drop off in reproduce head output normally starts at the highest frequency which must be reproduced, and is constant regardless of tape speed. Thus as the upper frequency requirement is extended, the lower frequency limit—dictated by the required signal-to-noise ratio rises inexorably with it, octave for octave. A general rule is that the maximum bandwidth which can be effectively reproduced by any magnetic tape device is approximately ten octaves.

It should now be apparent that compromises are necessary in designing a magnetic tape recorder for a given purpose. If a high frequency requirement is imposed, then low frequency, signal-to-noise, or distortion must be limited (or perhaps a modulating-demodulating system employed which will effectively compress the bandpass requirements). Conversely, a low frequency requisite limits the high frequency response which can be obtained.

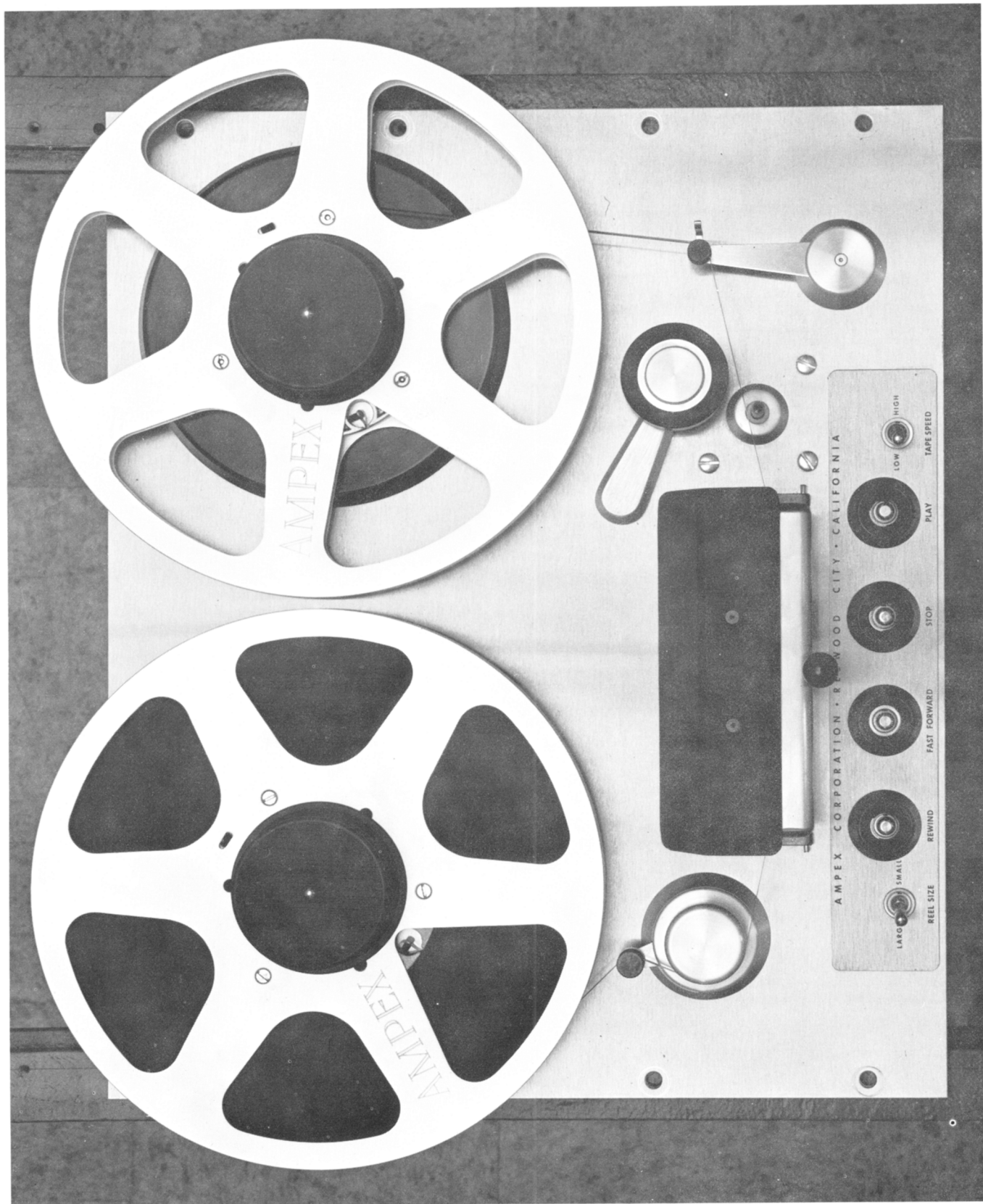

*Tape transport mechanism*