

ELECTRONIC MAINTENANCE**5.1 PREVENTIVE MAINTENANCE**

Preventive maintenance of the electronic assembly consists only of keeping the assembly clean. Remove the covers at frequent intervals and remove any accumulations of dirt and dust, using a small brush or vacuum cleaner. Do not use the blower action of a vacuum cleaner (or any other compressed air device) in cleaning, because particles of dust might be blown into critical areas -- such as bearings -- on the tape transport.

5.2 CHECKOUT AND ADJUSTMENT**5.2.1 General**

The checkout and adjustment procedures which follow are described for a record/reproduce equipment. There should be little difficulty in relating these instructions to the relatively simple adjustment of a reproduce-only unit.

In aligning the equipment, the playback function is first aligned to a standard by using an Ampex Standard Tape. The record function is then aligned using the playback circuit as a reference.

Standard alignment tapes are precisely recorded in an Ampex laboratory under stringently-controlled conditions. They must be handled and stored with proper care if they are to retain their usefulness over extended periods of time. Heads and tape guides should be cleaned and demagnetized before the standard tape is installed on the equipment, and the tape should not be stored

where temperature and humidity extremes occur. Also, the tape should be stored under the tape tension encountered in a normal play run, not after being rewound. After extended use, the response will begin to fade -- for example, the head azimuth tone on the standard tape may be down as much as 2 db.

When the standard tape is first run, it should be moved in the fast forward mode to the take-up side, then rewound to another reel (not the standard tape reel). The standard tape reel is then placed on the takeup turntable and tape threaded to it. This allows storage on the original reel without rewinding. Subsequent runs are made by putting the standard tape on the takeup turntable and rewinding to an empty reel on the supply turntable before proceeding with the reproduce alignment.

5.2.2 Test Equipment Required

D-C Voltmeter, 20,000 ohms-per-volt
A-C Vacuum Tube Voltmeter, Hewlett-Packard Model 400D or equivalent
Ampex Standard Alignment Tapes as applicable

15 ips NAB No. 01-31311-01
15 ips CCIR No. 01-31313-01
15 ips AME No. 01-31312-01
7-1/2 ips NAB No. 01-31321-01
7-1/2 ips CCIR No. 01-31323-01
3-3/4 ips (120 μ sec) No. 01-31331-01
3-3/4 ips (200 μ sec) No. 01-31334-01

- *Current probe (for vtm)
- *Electronic Counter
Signal Generator, Hewlett-Packard Model
200C or equivalent
- *Bias Filter (see Fig. 5-3)
- *Noise Filter (see Fig. 5-4)
- *Wave Analyzer
Normal tools used by technician.
- *If available.

5.2.3 Test Conditions

LINE TERMINATION switch on back of electronics in ON position to terminate equipment during all checks.

INPUT SELECTOR switch on back of electronics in UNBAL BRIDGE position during all checks.

Heads cleaned and demagnetized before starting checks.

Top and bottom covers installed on electronics during checks.

All record tests made with professional grade magnetic tape such as Ampex No. 631 or equivalent.

5.2.4 Voltage Regulator Adjustment

Proper operation of the voltage regulator can be checked at the octal socket for accessories (J7) at the back of the electronic assemblies.

Step 1: At the transport, select the low tape speed.

Step 2: Use pressure sensitive tape to hold the takeup tension arm away from its rest position, so that it does not contact the safety switch.

Step 3: Place the RECORD SELECTOR switches for all electronic assemblies in the READY position. Press the Play pushbutton on the transport and the RECORD pushbutton on the master electronic assembly. (The equipment will be in the record mode with the capstan idler against the capstan, and both reel motors operating.)

Step 4: Check the voltage from pin 7 (positive) of the octal socket to chassis ground, using the d-c voltmeter. It should be 23 volts (± 1 volt).

If the need for adjustment is indicated, remove the top service cover from the electronics assembly to gain access to the printed circuit board of that assembly. Repeat Steps 1, 2, and 3 previously described, checking the voltage from terminal 48 (positive) of the printed circuit

board to chassis ground. Adjust R77 (see Fig. 5-1) on the printed circuit board to achieve a 23 volt indication ($\pm 1/2$ volt) on the voltmeter.

Repeat the procedure for the other electronic assembly if this is a two channel equipment.

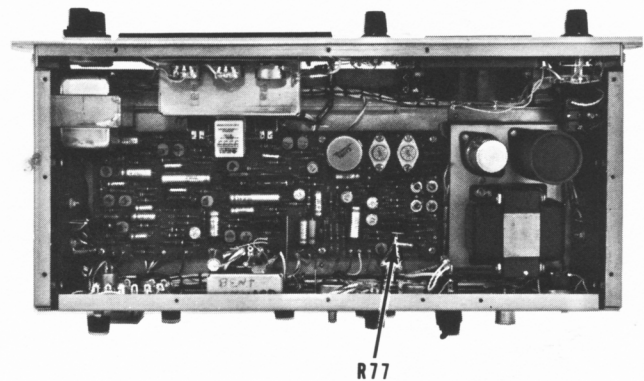

Fig. 5-1 *Voltage Regulator Adjustment Point*

5.2.5 Reproduce Alignment

Standard tape speeds available with this equipment are 3-3/4 - 7-1/2 ips and 7-1/2 - 15 ips. Because the 7-1/2 ips speed is common to either version, and will provide an optimum setting of controls, the reproduce alignment will be started with that speed.

Step 1: At the back of the electronic assembly, connect the vtm to the line OUTPUT connector. Terminate the output by placing the LINE TERMINATION switch in the ON position.

Step 2: Remove the head cover by removing the two screws on the top of the cover, and carefully lifting it up and off.

Step 3: Thread the 7-1/2 ips Ampex Alignment Test Tape on the tape transport.



WHENEVER A STANDARD TAPE IS THREADED ON THE TRANSPORT, ALWAYS CHECK THAT THE RECORD SELECTOR SWITCHES ON ALL ELECTRONIC ASSEMBLIES ARE IN THE SAFE POSITION.

Step 4: Select the 7-1/2 ips speed at the transport and place the OUTPUT SELECTOR switch

(not provided on reproduce-only equipment) in the REPRODUCE position. Start the standard tape in motion in the reproduce mode.

Step 5: The first tone on the standard tape is at 700 cps. Adjust the REPRODUCE LEVEL control to achieve any convenient indication on the vtm.

Step 6: The next tone is at 15,000 cps. As this signal is reproduced, adjust the reproduce head azimuth (see Fig. 5-2) to achieve a maximum indication on the vtm. If the head azimuth is far out of adjustment, minor peaks will be observed on each side of the correct setting; the correct adjustment will be unmistakable, however, for it will result in a vtm indication obviously higher than the minor peaks.

CAUTION

DO NOT TAMPER WITH ANY SCREW ON THE HEAD ASSEMBLY OTHER THAN THE ONE FOR AZIMUTH ADJUSTMENT.

Step 7: If this is a two-channel equipment, repeat Steps 1, 4, 5, and 6 for the second channel. If the head azimuth does not peak at exactly the same setting, a compromise adjustment between the two heads in the stack must be made.

Step 8: After completing the reproduce head azimuth adjustment, rewind the standard tape to the beginning of the first tone and replace the head cover.

Step 9: Remove the cover on the front panel of the electronic assembly by removing the two screws which secure it to the panel.

Step 10: Start the tape in motion in the reproduce mode. As the 700 cycle tone is reproduced, set the REPRODUCE LEVEL control to achieve a convenient reference indication on the vtm (i. e., -2 or -6 dbm).

Step 11: Check response as the balance of the tones on the standard tape are reproduced. Adjust the appropriate REPRODUCE HIGH FREQUENCY equalizer as required to achieve the flattest possible response (within specifications). However, do not adjust the equalizer more than ± 2 db from the theoretical curves shown on Figs. 8-7 and 8-8.

NOTE

When half track or two track heads are employed, readings below 700 cps (7-1/2 and 15 ips) or 500 cps (3-3/4 ips) are invalid when reproducing a standard tape. These tapes are recorded full track, and the "fringing" effect that occurs results in high indications at lower frequencies. This effect does not occur when tapes are recorded and reproduced using heads of the same configuration.

Step 12: As the 700 cycle tone at operating level is reproduced, turn the REPRODUCE LEVEL control to the CAL mark and adjust the REP CAL control as necessary to achieve a +8 or +4 dbm indication on the vtm (level will depend on whether the equipment is strapped for a +8 or +4 dbm operating level output). The equipment vu meter should indicate 0, $\pm 3/4$ db.

NOTE

On reproduce-only equipment there is no REP CALIB control. As the 700 cps tone is reproduced, simply adjust the REPRODUCE LEVEL control for the indicated output.

Step 13: Allow the tape to continue in motion in the reproduce mode until it is completely wound on the supply reel.

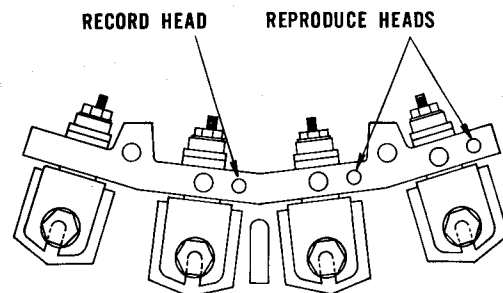
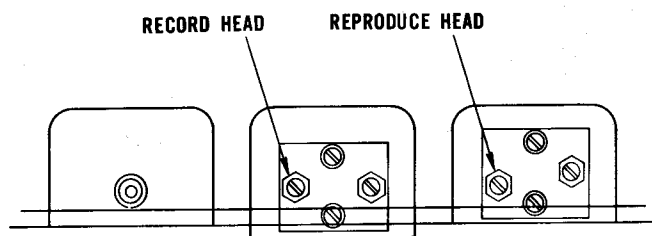

Fig. 5-2 Head Azimuth Adjustment Points

Step 14: Repeat Steps 8 and 11 for the second speed, using the appropriate standard alignment test tape.

Step 15: Repeat Steps 8, 9, 10, 11, 12, and 13 for the second electronic assembly if this is a two channel recorder.

5.2.6 Record Bias Oscillator Frequency and Erase Current Adjustment

This adjustment, which is not applicable to reproduce-only equipment, is made at the factory using a current probe, electronic counter, and vtvm, and placing one channel at a time in the record mode. If such equipment is available, check the erase current at the back of the erase head connector (with the erase head connected); it should be 60 milliamperes (± 5 ma). Then check the frequency, which should be 100,000 cps ($\pm 5,000$ cps). If adjustment is required, set ERASE ADJ control C36 to achieve the 60 ma erase current and BIAS FREQ control C34 so that the frequency is as close as possible to 100,000 cps. Then readjust C36 for correct erase current.

NOTE

If this is a two channel recorder, the bias oscillator frequencies in the two electronic assemblies must be identical within 1,000 cps.

If the test equipment used at the factory is not available, do not tamper with the adjustment of C34 or C36 unless erase efficiency is impaired or a beat frequency (when simultaneously recording and reproducing on both channels of a two channel equipment) becomes noticeable. In either case, adjust ERASE ADJ control C36 for a 40 volt (± 1 volt) erase level, measuring with the vtvm at the back of the erase head connector (with the erase head connected). On two channel equipment, adjust BIAS FREQ control C34 to eliminate the beat frequency, then re-check the setting of C36.

5.2.7 Record Bias Adjustment

NOTE

On this and other record adjustments, blank tape is specified. Tape used can be either

blank (bulk erased) or recorded with information not necessary to save (it will be erased during the record process). However, always bulk erase tape if it was recorded with a head configuration different from that on the equipment under test (the original recording might not be completely erased on the equipment).

This is a critical adjustment which must be made with the type of tape which will normally be used. It is not applicable to reproduce-only equipment.

Step 1: At the electronic assembly for the channel to be tested, place the RECORD SELECTOR switch in the READY position and the OUTPUT SELECTOR switch in the REPRODUCE position.

Step 2: Apply power to the equipment and select the 7-1/2 ips tape speed.

Step 3: Connect the signal generator to pins 1 and 3 of the line INPUT connector for the channel under test. Set it to 500 cps at a nominal 1 volt level.

Step 4: Connect the vtvm to the line OUTPUT of the channel under test.

Step 5: Thread blank tape on the equipment.

Step 6: Place the tape in motion in the record mode. Adjust the RECORD LEVEL control to achieve a convenient vtvm indication.

NOTE

Record only on the channel being tested.

Step 7: While thus simultaneously recording and reproducing, adjust the BIAS ADJ control for a peak vtvm indication.

Step 8: Turn the OUTPUT SELECTOR switch to the BIAS position. Adjust the BIAS CAL control, on the back panel of the electronic assembly, so that the vu meter indicates 0.

Leave test equipment connected for subsequent test procedures.

5.2.8 Record Level Adjustment and Calibration

The reproduce level must be adjusted (see paragraph 5.2.5) before starting this procedure, which is not applicable to reproduce-only equipment.

Step 1: Repeat Steps 1 through 5 of the record bias adjustment procedure (refer to paragraph 5.2.7). Leave the signal generator on 500 cps at a nominal 1 volt level.

Step 2: Start tape in motion in the record mode.

Step 3: While thus simultaneously recording and reproducing, turn the RECORD LEVEL control to achieve either a +8 or +4 dbm indication on the vtvm (level will depend on whether the particular equipment is strapped for a +8 or +4 dbm operating level output).

Step 4: Turn the OUTPUT SELECTOR switch to the INPUT position, and adjust the REC CAL control for a 0 indication on the vu meter.

Step 5: Repeat the procedure for the second channel if this is a two channel equipment.

Leave test equipment connected for subsequent checks.

5.2.9 Record Head Azimuth Adjustment

This adjustment is not applicable to reproduce-only equipment.

Step 1: Repeat Steps 1 through 5 of the record bias adjustment procedure (refer to paragraph 5.2.7). Set the signal generator to 15,000 cps at a nominal 1 volt level, and adjust the RECORD LEVEL control to obtain a -10 indication on the vu meter with the OUTPUT SELECTOR switch in the INPUT position.

Step 2: Remove the head cover by removing the two screws at the top of the cover and carefully lifting it off.

Step 3: Place tape in motion in the record mode. Place the OUTPUT SELECTOR switch in the REPRODUCE position.

Step 4: While thus simultaneously recording and reproducing, adjust the record head azimuth (see Fig. 5-2) to achieve a maximum vtvm indication. There may be minor peaks if the azimuth is far out of adjustment, but the correct setting will

result in an output obviously higher than the minor peaks.

CAUTION

DO NOT TAMPER WITH ANY SCREW ON THE HEAD OTHER THAN THE ONE FOR AZIMUTH ADJUSTMENT.

Step 5: Repeat the procedure for the other channel if this is a two channel equipment. If the azimuth does not peak at exactly the same setting, a compromise adjustment between the two heads in the stack must be made.

Step 6: Replace the head cover.

Leave test equipment connected for subsequent checks.

5.2.10 Low Frequency Reproduce Equalization Adjustment

Step 1: Repeat Steps 1 through 5 of the record bias adjustment procedure. Set the signal generator to 500 cps at a nominal 1 volt level.

Step 2: Place tape in motion in the record mode. Simultaneously record and reproduce at normal level.

Step 3: Change the frequency of the signal generator as required and adjust the 7-1/2 ips REPRODUCE LOW FREQUENCY equalizer for the flattest possible response from 250 cps to 30 cps in accordance with specifications. This is accomplished by adjusting for equal levels of the positive head bump peaks and negative head bump dips.

Step 4: Repeat Steps 1, 2, and 3 for the second speed, adjusting the appropriate reproduce low frequency equalizer.

Step 5: Repeat the entire procedure for the other channel if this is a two channel equipment.

On reproduce-only equipment, record frequencies from 250 to 30 cps on a properly adjusted record unit which has the same head configuration as the reproducer. Adjust the low frequency equalizer while reproducing this tape. If a record unit is not available thread the appropriate standard alignment tape on the equipment and adjust the low frequency equalizer for the output indication shown on Table 5-1 when the 50 cycle tone is reproduced.

Table 5-1. Low Frequency Equalization Response Using Standard Alignment Tape

TAPE SPEED	HEAD	RESPONSE (50 cps)
15 ips	Full Track	0 db
15 ips	Half Track	+2.5 db
15 ips	Two Track	+2 db
7-1/2 ips	Full Track	0 db
7-1/2 ips	Half Track	+2 db
7-1/2 ips	Two Track	+2 db
3-3/4 ips	Full Track	0 db
3-3/4 ips	Half Track	+1 db
3-3/4 ips	Two Track	+1 db

5.2.11 Record Equalization Adjustment

This procedure, which is not applicable to reproduce-only equipment, is most easily made by using a bias filter (see Fig. 5-3). If such a filter cannot be constructed, a trial-and-error method must be employed where the tape is first recorded as in Steps 2, 3, and 4 at different settings of the record equalization, then reproduced to determine proper setting.

Step 1: Repeat Steps 1 through 5 of the record bias adjustment procedure (refer to paragraph 5.2.7) inserting the bias filter between the OUTPUT connector and the vtm. Set the generator to 500 cps at a nominal 1 volt level.

Step 2: Place the OUTPUT SELECTOR switch in the INPUT position and adjust the RECORD LEVEL control for a -10 or a -14 dbm output as indicated on the vtm (level will depend on whether the equipment is strapped for a +8 or +4 db operating level output). Return the OUTPUT SELECTOR switch to the REPRODUCE position.

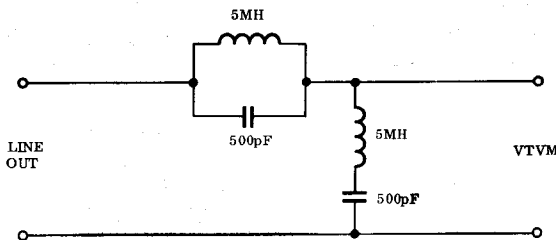

Fig. 5-3 Bias Filter

Step 3: Place the tape in motion in the record mode.

Step 4: While thus simultaneously recording and reproducing, change the frequency of the signal generator as required, and adjust the RECORD EQUALIZATION control for the flattest possible high frequency response in reference to 500 cps, in accordance with specifications.

Step 5: Repeat Steps 1 through 4 for the second speed.

Step 6: Repeat the entire procedure for the other channel if this is a two channel equipment.

5.2.12 Distortion and Noise Balance Adjustment

This adjustment, which is not applicable to reproduce-only equipment, is made at the factory using a signal generator with a second harmonic distortion less than 0.2% and a wave analyzer. Bias symmetry control R84 is adjusted for minimum second harmonic distortion of a 500 cps signal at 7-1/2 ips, placing only one channel at a time in the record mode.

If the test equipment used at the factory is unavailable, do not tamper with the adjustment of R84 unless some component in the bias and erase oscillator is changed. After completing such corrective maintenance, simultaneously record and reproduce with no input signal while monitoring the reproduce output through a high gain amplifier and loudspeaker (or head set). Adjust BIAS SYMMETRY control R84 for a minimum popping or hissing noise.

NOTE

If the symmetry control has no audible effect, simply leave it in the midposition.

5.3 **OVERALL PERFORMANCE CHECKS**

5.3.1 Test Equipment Required

- Signal Generator, Hewlett-Packard Model 200C or equivalent
- *Bias Filter (see Fig. 5-3)
- A-C Vacuum Tube Voltmeter, Hewlett-Packard Model 400D or equivalent
- Bandpass Filter (See Fig. 5-4)
- *Wave Analyzer

*If available

5.3.2 Test Conditions

LINE TERMINATION switch on back of electronics in ON position to terminate equipment during all checks.

INPUT SELECTOR switch on back of electronics in the UNBAL BRIDGE position.

Heads cleaned and demagnetized before starting checks.

Top and bottom covers installed on electronics during checks.

All record tests made with professional grade-magnetic tape such as Ampex No. 631 or equivalent.

5.3.3 Overall Frequency Response Check

This check can be made while simultaneously recording and reproducing if the bias filter (see Fig. 5-3) is available. If this is not the case, record the tape and then rewind and make the response run.

On reproduce-only equipment the response check can be made by recording the tape on a properly adjusted recorder with the same track configuration as the reproducer. If such a recorder is unavailable, make the check with a standard tape (refer to paragraph 5.2.5) -- keeping in mind the low frequency limitations noted for such a tape.

Step 1: Connect the signal generator to pins 1 and 3 of the line INPUT connector for the channel under test. Set it to 500 cps at a nominal 1 volt level.

Step 2: Connect the bias filter to the corresponding line OUTPUT connector, and connect the vtm to the output of the filter.

Step 3: Place the OUTPUT SELECTOR switch in the INPUT position and adjust the RECORD LEVEL control for a -10 or -14 dbm output as indicated on the vtm (level is dependent on whether the equipment is strapped for a +8 or +4 db operating level output). Then turn the OUTPUT SELECTOR switch to the REPRODUCE position.

Step 4: Place the RECORD SELECTOR switch of the channel being tested in the READY condition.

Step 5: Thread blank tape on the equipment and select the 7-1/2 ips tape speed.

Step 6: Place the tape in motion in the record mode.

Step 7: While thus simultaneously recording and reproducing, change the signal generator frequency in discrete steps from 30 to 15,000 cps. The response, as indicated on the vtm, should be within the tolerances quoted in specifications (refer to Section 1).

Step 8: Select the second speed and repeat Steps 6 and 7. Note that if the second speed is 3-3/4 ips, the record level as quoted in Step 3 is correct. If it is 15 ips that level may be increased to 0 or -4 dbm (depending on output strapping) as indicated on the vtm. Make the response run from 50 to 7,500 cps for the 3-3/4 ips speed, from 30 to 18,000 cps at the 15 ips speed.

Step 9: Repeat the entire procedure for the other channel if this is a two channel equipment.

Poor frequency response can result from any of the causes listed below:

- a. Heads in need of demagnetization (refer to Section 6).
- b. Heads in need of cleaning (refer to Section 6).
- c. Head azimuths incorrectly adjusted (refer to paragraphs 5.2.5 and 5.2.9).
- d. Bias level incorrectly adjusted (refer to paragraph 5.2.7).
- e. Reproduce equalization incorrectly adjusted (refer to paragraphs 5.2.5 and 5.2.10).
- f. Record calibration incorrectly adjusted (refer to paragraph 5.2.8).
- g. Record equalization incorrectly adjusted (refer to paragraph 5.2.11).
- h. Play holdback tension incorrectly adjusted (refer to Section 4).
- i. Magnetic tape not professional quality.
- j. Signal generator output not flat over response spectrum.

5.3.4 Overall Signal-to-Noise Check

To make this check it is required that an output bandpass filter be employed. A

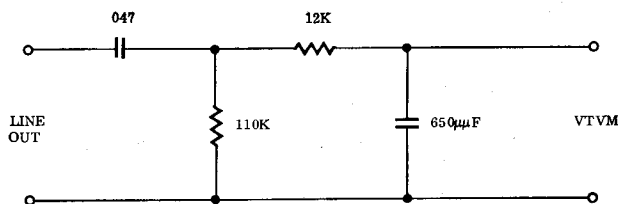

Fig. 5-4 Noise Filter

schematic diagram of the necessary filter is shown on Fig. 5-4.

Step 1: Connect the signal generator to pins 1 and 3 of the line INPUT connector for the channel under test. Set it to 500 cps at a nominal 1 volt level.

Step 2: Connect the bandpass filter to the corresponding line OUTPUT connector, and the vtvm to the output of the filter.

Step 3: Place the OUTPUT SELECTOR switch in the INPUT position and adjust the RECORD LEVEL control for a +14 or +10 dbm output (depending on whether the equipment is strapped for a +8 or +4 dbm operating level output).

Step 4: Place the RECORD SELECTOR switch in the READY position.

Step 5: Thread blank tape on the equipment and select the 7-1/2 ips tape speed. Close the head gate.

Step 6: Place tape in motion in the record mode and record a section of the tape with the 500 cps signal.

Step 7: Rewind the tape to the beginning of the recording made in Step 6. Remove the signal generator. Place the OUTPUT SELECTOR switch in the REPRODUCE position. Close the head gate.

Step 8: Start tape in motion in the record mode with no input signal. The noise level, while thus erasing the 500 cps recording, will be indicated on the vtvm.

NOTE

The signal-to-noise ratio is computed from peak record level, which is 6 db higher than normal record level. Therefore, add 14 db (+8 dbm output) or 10 db (+4 dbm output) to the vtvm indication in Step 8 to determine the actual signal-to-noise ratio.

Step 9: Repeat Steps 6, 7, and 8 for the second speed.

Step 10: Repeat the entire procedure for the other channel if this is a two channel equipment.

The signal-to-noise ratio should meet specifications (refer to Section 1).

An inadequate signal-to-noise can result from any of these causes:

- a. Heads in need of demagnetization (refer to Section 6).
- b. Heads in need of cleaning (refer to Section 6).
- c. Incorrect bias symmetry adjustment (refer to paragraph 5.2.12).
- d. Magnetic tape not professional quality.
- e. External fields from nearby motors, generators, etc.
- f. Head cables rubbing against moving parts on transport.
- g. Making noise run with head gate open.

To check reproduce noise, remove the tape from the equipment. Connect the vtvm to the line output connector and hold the takeup tension arm away from its rest position (so that it does not contact the safety switch). Press the Play pushbutton and read the noise on the vtvm. Under these circumstances the signal-to-noise should be as shown in Table 5-2.

Table 5-2. Reproduce Noise

TAPE SPEED	HEAD	REPRODUCE SIGNAL/NOISE
15 ips	Full Track	63 db
15 ips	Half Track	58 db
15 ips	Two Track	58
7-1/2 ips	Full Track	63 db
7-1/2 ips	Half Track	58 db
7-1/2 ips	Two Track	58 db
3-3/4 ips	Full Track	58 db
3-3/4 ips	Half Track	53 db
3-3/4 ips	Two Track	53 db

5.3.5 Overall Distortion Check

An accurate check of distortion on this equipment requires the use of a wave analyzer to measure individual distortion products. (An instrument which measures total harmonic distortion will be influenced by tape noise and modulation noise in addition to actual distortion.) Also, the signal generator must have very low distortion (less than 0.1%) or addition and cancellation effects can occur.

To check distortion, record a 500 cps signal on blank tape at normal operating level. On playback, the second harmonic component should not exceed 0.4%, the third harmonic between 0.6% and 1.1%. The most common cause of any higher second harmonic distortion reading is a magnetized record head, but it could also result from a malfunctioning record or reproduce amplifier, or a non-symmetrical bias waveform.

Third harmonic distortion is dependent on the type of magnetic tape employed, the bias setting, and the accuracy with which the "normal operating level" is adjusted. A typical roll of tape will have a 500 cps third harmonic content of 0.8% at operating level, but this might range as high as 1.1%.

5.4 PRINCIPLES OF OPERATION

5.4.1 General

This discussion can be followed most easily by referring to the block diagrams of Figs. 5-5 and 5-6, and the schematic diagrams of Figs. 7-3 through 7-7. Because there is considerable difference in the reproduce circuit between the record/reproduce and reproduce-only equipment, the two will be described separately.

On the record/reproduce assembly, numbers preceding the reference symbol refer to the physical location of the component. Symbols preceded by 1 (1Q1, 1R31, etc.) indicate the component is on the printed circuit board. A 2 indicates location on the front panel, 3 on the left panel (when facing the front), 4 on the back panel, 5 on the right panel, and 6 on the power supply.

On two channel equipment one electronics assembly will be a "master" unit, the other a "slave" unit. The only differences between the two is that power application and entrance into the record mode is controlled at

the master. A-c power is connected to the master, and routed from there to the tape transport and the slave assembly.

5.4.2 Power Supply

Line power is connected to the electronic assembly at 4J10, and is then connected through POWER switch 2S4 and fuse 4F2 across the primary of power transformer 6T3. (From the switch, a-c power is also delivered to the tape transport through fuse 4F1 and connector 4J9.)

One secondary winding of transformer 6T3 is connected to the lights on the vu meter, which act as a power indicator. The other secondary winding is across a bridge rectifier, consisting of diodes 1CR3 through 1CR6. After rectification, power is routed to a voltage regulator circuit.

In the voltage regulator, the reference voltage is established by zener diode 1CR10, and the sampling voltage is taken at variable resistor 1R77 (which provides the voltage adjustment). If the output voltage tends to vary with load, the conductance of transistor 1Q22 will change. This in turn affects the conductance of transistors 1Q21 and 3Q20, connected in a Darlington circuit, so that the voltage is returned to the normal level.

Transistor 1Q19 acts as a constant current source. Diode 1CR9 and resistor 1R74 provide overload protection. If the current through 1R74, combined with that through 1R73, results in a voltage sufficient to break down 1CR9, transistor 1Q19 will be biased toward cutoff. This in turn will under bias the rest of the transistors in the regulator.

A +23 volt regulated output is delivered to the speed switch on the tape transport, and used to energize equalization relay 2K1 in the low speed position of that switch. It is also routed to all stages in the reproduce amplifier, the octal socket for accessory input units, and the first three stages in the record amplifier.

When the channel is in the record mode, one contact of record relay 3K2 connects the power to the final two stages of the record amplifier, and through series transistor 1Q23 and fuse 4F3 to the bias oscillator. Those circuits thus will operate only when the channel is recording.

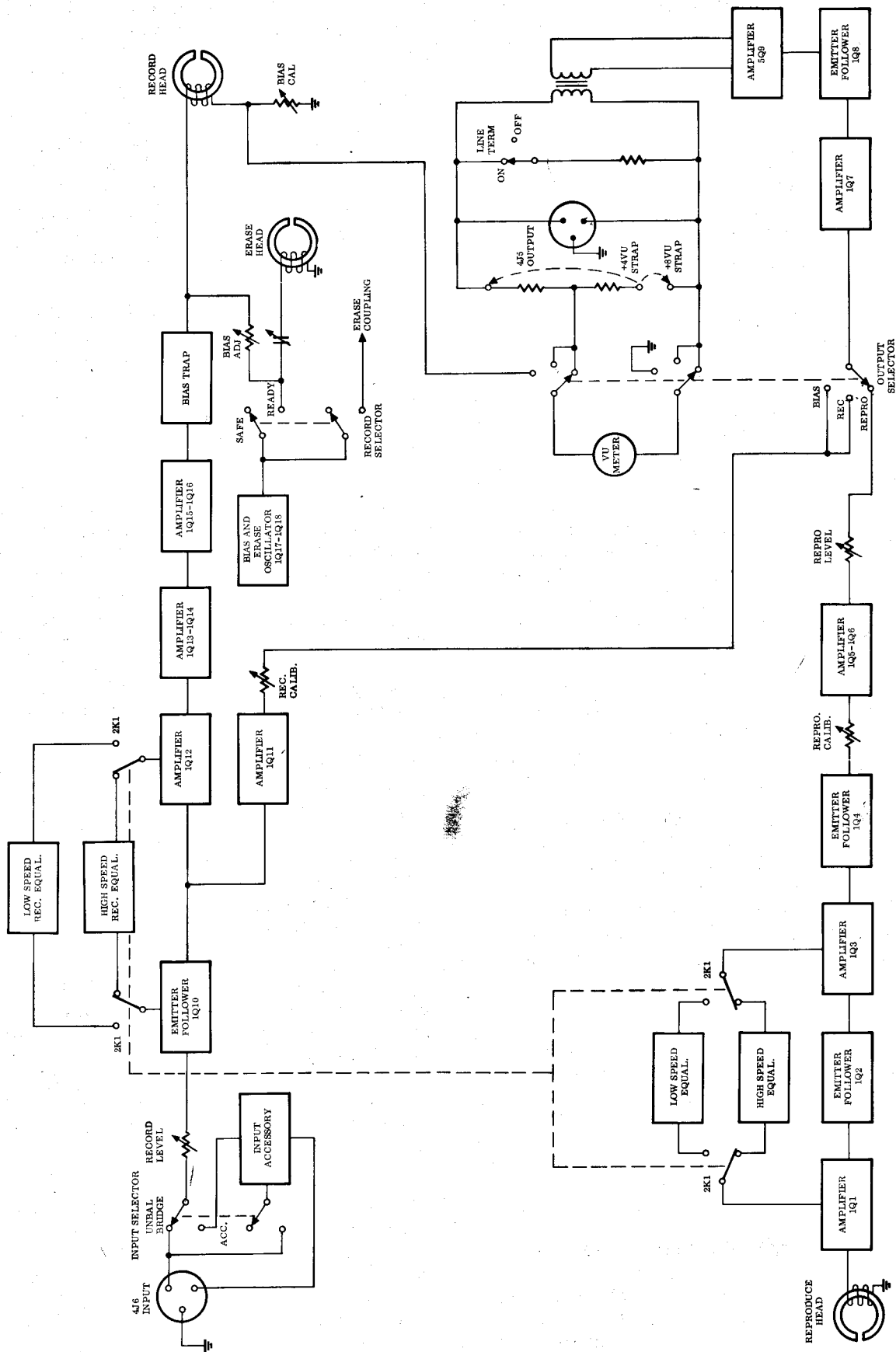

Fig. 5-5 Block Diagram, Record/Reproduce Electronic Circuit

NOTE

The power supply in a reproduce-only unit employs a very simple voltage regulator, consisting of a bridge rectifier, series power transistor, and a zener diode.

5.4.3 Record Circuit

The signal to be recorded is connected to the equipment at INPUT connector 4J6. From there it is connected to the INPUT SELECTOR switch 4S3. If the recording is from an unbalanced line this switch is placed in the UNBAL BRIDGE position, if it is from a balanced line or microphone, the switch is placed in the ACCESSORY position and the proper accessory plug-in unit (transformer or microphone preamplifier, see Section 1) is inserted in octal socket 4J7.

From the selector switch or accessory unit, the signal is routed through RECORD LEVEL control 2R38 to the base of emitter-follower stage 1Q10. From the emitter of 1Q10 the signal path splits. One path leads through the record calibrating amplifier 1Q11, whose gain is adjusted by RECORD CALIBRATE control 2R45, and through contacts of the OUTPUT SELECTOR switch 2S1 to the line amplifier -- through which it proceeds to the monitor jack, vu meter, and OUTPUT connector for monitoring purposes.

The second signal path from 1Q10 is through resistor 1R42 to the base of amplifier stage 1Q12. Note that record equalization consists of a variable capacitor (on the plug-in equalizers) selected by contacts of equalization relay 2K1; this capacitor is connected in parallel with 1R42 to provide the necessary high frequency pre-emphasis.

After amplification in 1Q12 the signal is connected to 1Q13 and 1Q14, which form a Darlington amplifier circuit. In such a circuit, the first transistor in the circuit (1Q13) provides a low impedance source for the second (1Q14). The resultant amplifier is characterized by very low noise. From this amplifier the signal proceeds to a constant current amplifier stage formed by 1Q15 and 1Q16.

In this constant current state, transistor 1Q15 acts as an active load resistance for the collector of 1Q16, providing a relatively low d-c resistance and a relatively high a-c re-

sistance. In the audio frequency range, therefore, the collector of 1Q16 works into an impedance which is sufficiently high to provide a constant current source for the record head, yet allows full utilization of the d-c operating voltage available.

From this stage the signal is routed through a bias trap, consisting of choke 1L1 and capacitor 1C27, to the record head. Operating voltage is delivered to 1Q13, 1Q14, 1Q15, and 1Q16 only when the channel is in the record mode, so those stages are inactive in any other mode.

The bias/erase oscillator, consisting of transistors 1Q17 and 1Q18, is a push-pull circuit connected as tuned flip-flop. Operating voltage is delivered only when the channel is in the record mode. Symmetry of the output waveform is adjusted at 4R84, and the frequency is adjusted at variable capacitor 4C34. The transformer-coupled output is delivered to the RECORD SELECTOR switch 2S5. When this switch is in the READY position, the oscillator output is routed through BIAS ADJUST resistor 2R68 to the record head, where it is mixed with the signal. It is also connected through ERASE ADJUST capacitor 4C36 to the erase head, and to the erase coupler jack (4J12). On two channel equipment the erase coupling jacks are employed to connect the two oscillators and thus lock their frequencies together; this prevents any beat frequency from being generated. When the RECORD SELECTOR switch is in the SAFE position the oscillator transformer, record head and erase head, and the coupling circuit, are disconnected from each other.

5.4.4 Reproduce Circuit (Record/Reproduce Equipment)

The signal from the reproduce head enters the electronic assembly at 4J1 and is amplified by transistor stage 1Q1. It is then routed through emitter follower 1Q2 to another amplifier (1Q3). The high speed or low speed equalization circuit, as selected by contacts of equalization relay 2K1, is connected from the collector of 1Q3 back to the emitter of 1Q1, and d-c feedback is provided through 1R4 between these two stages.

Transistor 1Q4 is another emitter follower, followed by REPRODUCE CALIBRATION control 2R15. The signal then proceeds to a Darlington amplifier, formed by transistors 1Q5 and 1Q6. In this circuit 1Q5 acts as a low impedance source for 1Q6 to produce amplification of the signal and low noise.

After amplification in 1Q5/1Q6, the amplitude is adjusted by REPRODUCE LEVEL control 2R21 and the signal then proceeds through contacts of the OUTPUT SELECTOR switch to amplifier stage 1Q7. The signal is next routed through emitter follower 1Q8 to the output amplifier stage 5Q9.

A monitor jack is connected in the collector circuit of 5Q9. Note that there is a small amount of d-c (approximately 1 volt) present at this jack. Headsets with impedances of 300 ohms or more may be used to monitor the signal.

The output signal is coupled through transformer 5T1 to the line OUTPUT connector 4J5. LINE TERMINATION switch 4S2 connects resistor 4R36 across the transformer secondary during test and adjustment procedures, or removes it during normal operation. If the equipment is operated into a high impedance load (2,000 ohms or more) switch 4S2 should be left in the ON position.

Visual monitoring of the signal is provided at the vu meter. Note that, depending on the position of the OUTPUT SELECTOR switch, the meter will indicate REPRODUCE level, record (INPUT) level, or BIAS level. (This switch also determines whether the reproduce or record signal is present at the monitor jack and the output connector.) The placement of straps in the meter circuit determines whether the meter indicates 0 at a +8 db level or a +4 db level. With the +8 db strapping, resistors 4R33 and 4R34 are connected as a voltage divider across the secondary of transformer 5T1, with the meter connection taken at the junction of the two resistors. For a +4 db output, the strapping connects 4R33 and 4R34 in parallel on one side of the line, and the meter is connected in series with this circuit.

In the BIAS position of the OUTPUT SELECTOR switch, resistor 2R37 is connected to the vu meter (it is shorted in any other switch position). This is simply to provide proper working impedance for the meter, when it is connected to the bias circuit.

5.4.5 Reproduce Circuit (Reproduce-only Equipment)

The signal reproduced from the tape enters the assembly at 2J1, and is amplified in stage 2Q1. It then proceeds through emitter follower stage 2Q2 to another amplifier, 2Q3. High speed or low speed equalization, selected by contacts of equalization relay 2K1, is connected from the collector of 2Q3 back to the emitter of 2Q1. D-C feedback is also provided between these two stages through resistor 2R9.

Amplitude of the signal is adjusted by REPRODUCE LEVEL control 2R14, followed by amplifier stage 2Q4. Emitter follower 2Q5 and output amplifier 2Q6 complete the circuit.

The output signal is coupled through transformer 2T1 to the line OUTPUT connector 2J2. The vu meter on this assembly is an optional accessory; if employed, meter strapping is the same as that explained in paragraph 5.4.4.

5.4.6 Record Control Circuit

The RECORD pushbutton is located on the master electronic assembly. To enter the record mode, RECORD SELECTOR switch 2S5 must be in the READY position (on two channel equipment either or both channels may be placed in the ready condition). After tape is started in motion in the play mode at the tape transport, pressing the RECORD pushbutton will place any channel which is in the ready condition into the record mode.

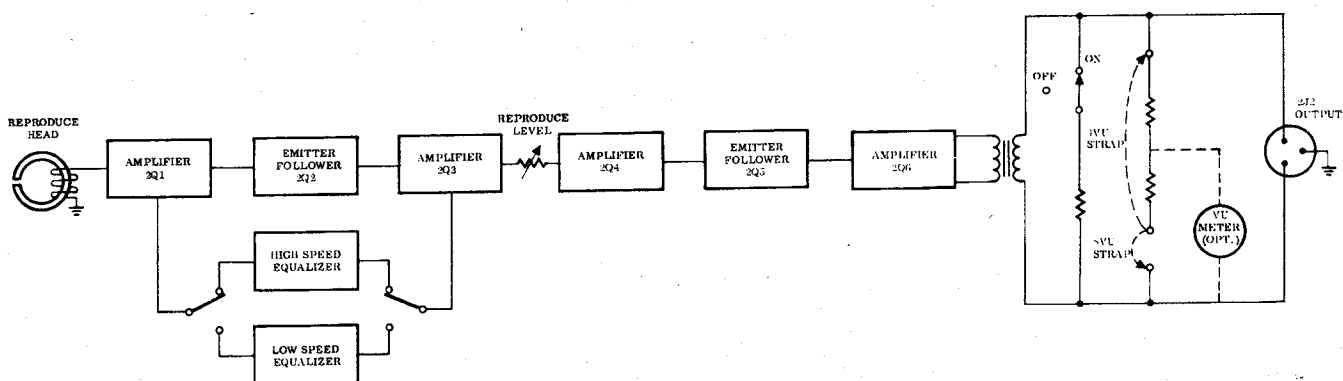

Fig. 5-6 Block Diagram, Reproduce-only Electronic Circuit

When the pushbutton is pressed, record relay 3K2 is energized. One of its contact sets forms a holding circuit and another contact set switches power to the record and bias oscillator circuits. The equipment will thus be placed in the record mode, on the channels which were placed in the ready condition (any

channel, including the master, which is left in the "safe" condition will not be recording).

Indicator lights 2I2 and 2I1 show when a channel is in the ready condition or in the record mode respectively.