

SERVICE BULLETIN

AMPEX

AUDIO PRODUCTS DIVISION • AMPEX PROFESSIONAL PRODUCTS COMPANY

DATE	2/10/55
MODEL	350/351
BULLETIN NO.	5-01
PAGE NO.	1 of 1

CAPSTAN SHAFT SLIPPAGE

Occasionally, after considerable use, a capstan shaft will become overly polished. The result is that the recorder will not meet the starting specifications. The slippage is sufficient to reduce the speed of the tape by 1% for the first two seconds.

There are two solutions for correcting this slippage problem.

- (1) Replacement of the capstan motor for one having the correct capstan finish.
- (2) Vigorously roughen the capstan with emery paper so that the scratches lie parallel to the axis of the shaft. (Use Wetordry Tri-M-It Paper, waterproof silicon carbide, 320A soft back, Minnesota Mining and Manufacturing Company, or equivalent.) However, great care should be exercised to prevent any particles of the emery paper from dropping into the capstan bearing. Therefore it is recommended that the following procedure be followed when roughening capstan shafts with emery paper.
 - (1) Place the top plate so that the capstan shaft is parallel to the floor.
 - (2) Cover the capstan shaft opening with a rubber cap with a hole punched in it to assure a snug fit and further prevent particles from reaching the capstan bearing.

It is very easy to get a smooth, satiny roughness in this manner without having to remove and replace capstan motor assemblies.

AMPEX
CORPORATION

934 CHARTER ST. • EMERSON 8-1471
TWX REDWOOD CITY CAL 41
CABLE ADDRESS: AMPEX, REDWOOD CITY
REDWOOD CITY, CALIFORNIA

MAGNETIC RECORDERS

PROFESSIONAL PRODUCT

SERVICE BULLETIN

DATE: July 12, 1956
MODEL: General
BULLETIN NO: 8
PAGE NO: 1 of 1

HEAD ASSEMBLY CLEANING AGENT

Cleanliness of all parts of the tape drive mechanism is required for consistent optimum performance. Most tape manufacturers lubricate their tapes; this lubricant will gradually form a coating on the head assembly and the idler wheels and may cause loss of positive drive at the capstan. Therefore, periodic cleaning of both the head assembly and all parts of the tape drive mechanism is particularly important.

The recommended agent for cleaning Ampex Head Assemblies is a mixture of Xylene and 0.1% Aerosol.
(Ampex Catalog No. 087-007)

To clean any head assembly simply wind a clean, lintless cloth on a swab-stick and moisten with this mixture. Swab the heads periodically to remove all dirt and oxide which may have accumulated from the tape.

Caution: Do not use any other solvents as there are some which may damage the laminations of the head assembly.

Clean all parts except the head assembly with a clean, lintless cloth moistened with denatured alcohol.

SERVICE BULLETIN

AMPEX

AUDIO PRODUCTS DIVISION • AMPEX PROFESSIONAL PRODUCTS COMPANY

DATE September 6, 1956
MODEL General
BULLETIN NO. 6-02
PAGE NO. 1 of 1

TURNTABLE PIN

In recent months there have been a number of complaints of turntable pins shearing off under unusual operating conditions on some of the earlier versions of Models 300, 350 and S-3200.

While it is possible to replace these three small pins, a better solution is to install a single large pin, which is now available through all Authorized Service Representatives in Kit #17952-1. This Kit contains a Pin, a Nut and a Template.

To install the Pin, remove the Turntable Motor Assembly from the Tape Transport. Slide the Template over the motor shaft and mark the hole location lightly with a centerpunch at the point indicated by the cross (11/16" radius on the Turntable). Wrap a cloth around the motor to prevent drill chips from falling in. Drill a #28 hole to clear the 6-32 threads of the Pin.

The Pin should fit snugly against the Turntable. Therefore after drilling the hole it is necessary to enlarge the hole in the Pad to accommodate the 3/16" dia. Pin.

The Pin can then be inserted in the Turntable and held firmly with the 6-32 Nut provided.

SERVICE BULLETIN

AMPEX

AUDIO PRODUCTS DIVISION • AMPEX PROFESSIONAL PRODUCTS COMPANY

DATE March 19, 1958
MODEL General
BULLETIN NO. 8-04
PAGE NO. 1

SCALES FOR MEASURING TENSIONS AND BRAKES

Suitable scales for measuring tensions and brakes are available from the following:

JOHN CHATILLON & SONS
90 Cliff Street
New York City, N. Y.

<u>Chatillon Part No.</u>	<u>Description</u>	<u>Approximate Price</u>
8EG	0-8 oz., flat face	\$ 2.65
16EG	0-16 oz., flat face	2.65
9EG	0-64 oz., flat face	2.65
015	0-80 oz., cylindrical	12.00

PELOUZE MFG. CO.
1218 Chicago Avenue
Evanston, Ill.

<u>Pelouze Part No.</u>	<u>Description</u>	<u>Price</u>
5T	0-80 oz., cylindrical	\$ 10.00

THE EXACT WEIGHT CO.
917 W. Fifth Avenue
Columbus, Ohio

Postalett	0-8 oz.	(This scale is available at stationery suppliers)
-----------	---------	--

For information regarding dealers, it is suggested these companies be contacted.

SERVICE BULLETIN

AMPEX

AUDIO PRODUCTS DIVISION • AMPEX PROFESSIONAL PRODUCTS COMPANY

DATE	May 14, 1958
MODEL	350
BULLETIN NO.	8-01
PAGE NO.	1 of 1

LUBRICATING MODEL 350 DRIVE MOTORS

Model 350 drive motors manufactured by Ashland and IMC do not have oil holes for lubrication purposes.

The proper procedure for lubricating these motors is as follows:

Run the motor until normal operating temperature is reached. This usually will require ten to fifteen minutes of operation. Remove the dust cap and with the motor running place several drops of oil at the base of the capstan shaft. The oilite bearing can generally be observed at this point. Turn the motor off and allow it to cool. This draws the oil into the bearing proper.

The Bodine drive motors may be oiled in the same manner even though these motors have oil holes available.

The lower bearings on all Model 350 drive motors are permanently oiled, sealed bearings.

January 20, 1958

General

3-01

1 of 1

(Supersedes bulletin dated 20 March 1953)

**INSTALLATION OF GATE SPRINGS IN 475 SERIES
AND SIMILAR HEAD ASSEMBLIES**

Should it be necessary to replace the 438-1 gate springs, the following method has proven to be the most practical:

1. Pull the drive pins at each end of the gate and remove the gate.
2. The springs are placed in the gate post with the crimped section in the slot as shown. They should be held in place with a small piece of masking tape. Be careful to keep the springs as straight as possible with reference to the gate post.
3. Push the gate assembly into place, in open position and insert the springs in the stop post slots during the process.
4. Insert the drive pins in the gate ends, leaving about 1/16" of the drive pins extending. Remove the masking tape.

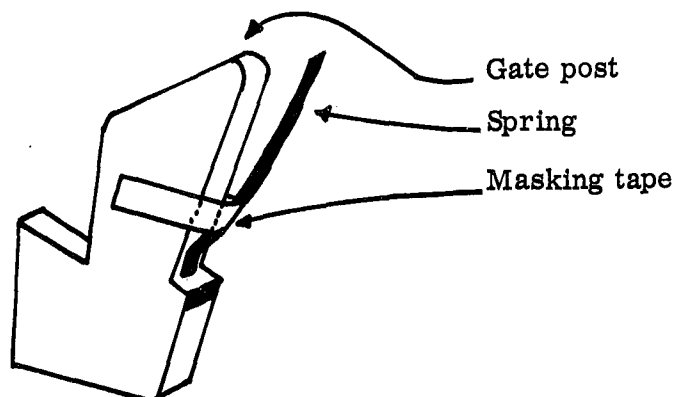

SERVICE BULLETIN

AMPEX

AUDIO PRODUCTS DIVISION • AMPEX PROFESSIONAL PRODUCTS COMPANY

DATE May 14, 1959
MODEL General
BULLETIN NO #9-01
PAGE NO. 1 of 1

MODEL 350, 351 AND 3200 SERIES

To furnish a practical alternate method of measuring and correcting torque adjustments on takeup and supply motors, substituting a voltmeter for a scale. The following curve indicates within $\pm 5\%$ the voltages measured across the motor windings for a given amount of torque.

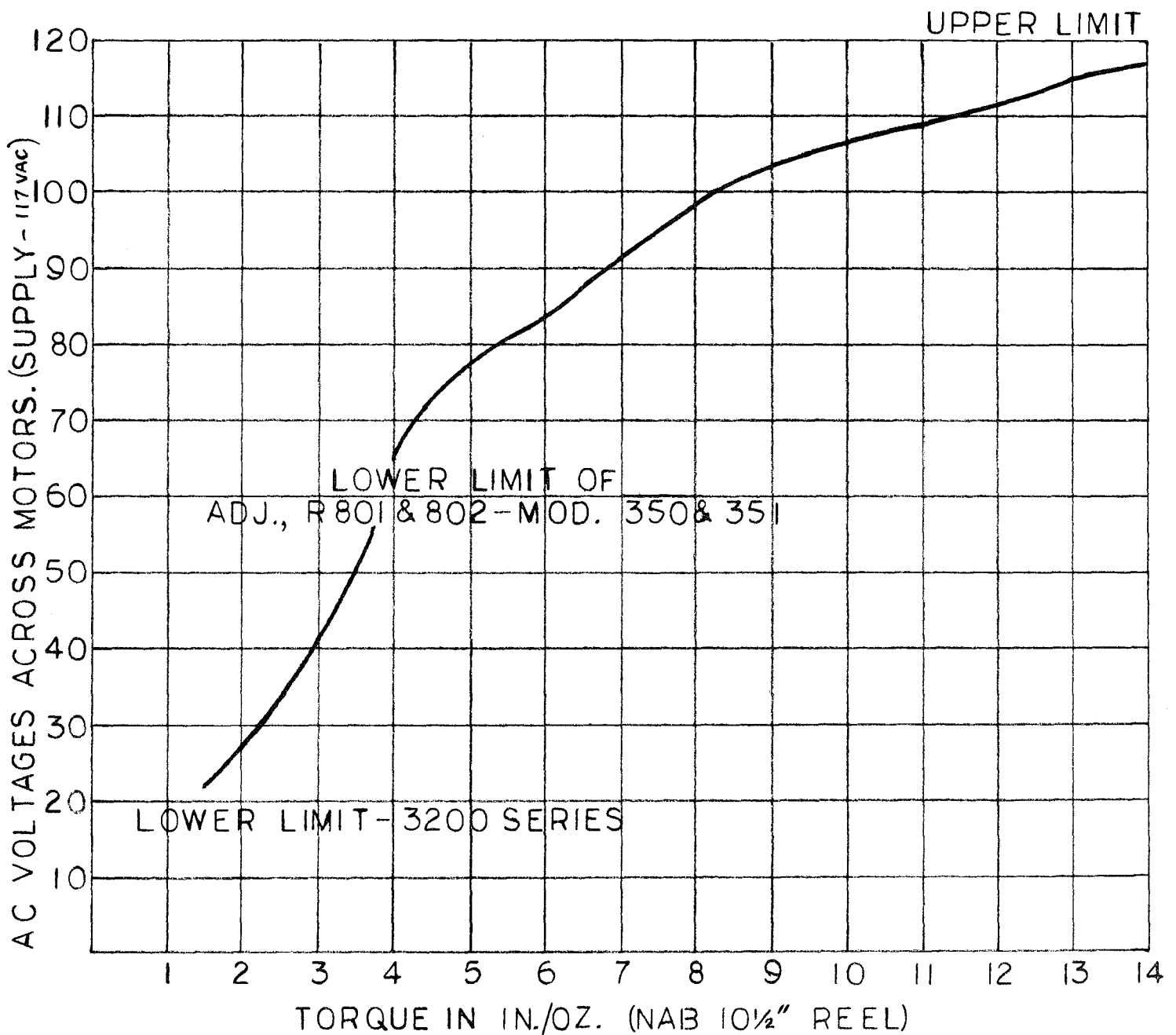

AMPEX

CORPORATION

*professional
products division***SERVICE BULLETIN**

934 CHARTER ST. • REDWOOD CITY, CALIF. • EMERSON 9-7111 • TWX REDWOOD CITY, CAL 41 • CABLE ADDRESS: AMPEX, REDWOOD CITY

Date: June 22, 1959
Model: 350/351
Bulletin 9-03
Page No. 1

TRANSPORT MODIFICATION FOR REMOTE CONTROL OPERATION

When Model 350/351 recorders with catalog number 5700 transports are used with a remote control system, the remote control lamp can cause a current drain in excess of the rating of R506, the 100 ohm, 1/2 watt resistor located in the transport relay control box, connected from pin 5 of J502S to pin 6 of J501S. It is recommended that this resistor be replaced with a 22 ohm, 1 watt resistor Ampex number OLC-132, if the recorder is to be used with the remote control.

This component change has been made in all catalog number 30970 transports.

SERVICE BULLETIN

AMPEX

AUDIO PRODUCTS DIVISION • AMPEX PROFESSIONAL PRODUCTS COMPANY

DATE July 1, 1959
MODEL 350/351
BULLETIN NO. #9-02
PAGE NO. 1 of 4

TRANSPORT CHANGES

Effective August 1, 1959, Model 351 recorders incorporate certain changes in circuitry of the control box to improve fast mode tape handling characteristics in small reel position. These transports also include an improved brake assembly which provides better braking action in all modes of operation. Transports with these changes are identified as Ampex catalog number 30970. The new control box is catalog number 5703-03. The circuit change can be made in any existing 350 or 351 transport, catalog number 5700, by rewiring the 5703 control box, as follows:

1. Remove control box from transport and take off screen.
2. Remove the gray jumper wire which runs between R502 and R503.
3. Disconnect the blue wire from the other end of R502 and pull out of hole in panel. Remove the sleeving for future use. Cut and tape the end of this wire.
4. Drill a hole with a #28 drill 1 inch above J504S (opposite lettered side). Be sure all components and wires are far enough removed to prevent damage from drill.
5. Remove the end plate carrying the 4 plugs by removing 4 screws along the side.
6. Mount a single lug terminal post using the hole just drilled.
7. Disconnect all wires leading to pins 8 and 9 of J501S and solder all of them to the new terminal lug.
8. Disconnect 100 ohm resistor from pin 7 of J503S and connect it to pin 8 of J501S.
9. Disconnect the two purple wires from the selenium rectifier. Cut 1" from harness, solder them together and tape over exposed ends.
10. Disconnect purple harness wire from pin 17 of J501S and connect to pin 8 of J501S. (Do not solder pin 8 now). Do not remove purple jumper wire from pin 7 J503P.

11. Connect pin 8 of J501S to one end of R502 and pin 9 of J501S to opposite end of R502. Use high temperature insulating sleeving, where wires go thru hole in panel and run wires directly thru the center of the box. They may be tied or taped together for neatness. Do not solder pins 8 and 9.
12. Connect a wire from pin 17 of J501S to the terminal of the selenium rectifier from which the two purple leads were removed.
13. Run a wire from pin 17 of J501S to pin 9 of J501S. Pins 8 and 9 should now be soldered.
14. Replace end panel and remount box on transport. Dress wires from R502 neatly thru center of box and against transport plate. Replace screen.

A simplified schematic of rewired control box is shown in figure 1.

The braking system of 350 or 351 transports may be converted to the improved system by installation of takeup brake assembly, catalog number 17327-01 and rewind brake assembly, catalog number 17327-02. Each assembly is pre-adjusted and includes:

Brake Housing	17614-01 (takeup only)
or Brake Housing	17614-02 (rewind only)
Brake Band	17612-01
Brake Band Leaf	61460-01
Brake Tension Spring, long	322-01
2 Brake Tension Spring, short	17323-00
Brake Solenoid	337-00

Installation of the new brake assemblies is accomplished, as follows:

1. Slip back the insulating sleeves on the harness wires and cut the solenoid leads 4" from the plug.
2. Remove the capacitor from the brake housing, if it is so mounted.
3. Remove the brake assembly by removing the mounting screws threaded into the motor housing. Save the screws and spacers for mounting on the new assembly.

July 1, 1959

Model: 350/351

Bulletin. #9-02

Page 3 of 4

4. Install the new brake assembly on the motor and mount the capacitor on the new assembly.
5. Connect the solenoid leads. Use tubing or tape to insulate connections.

MODIFIED A.C. CONTROL CIRCUIT

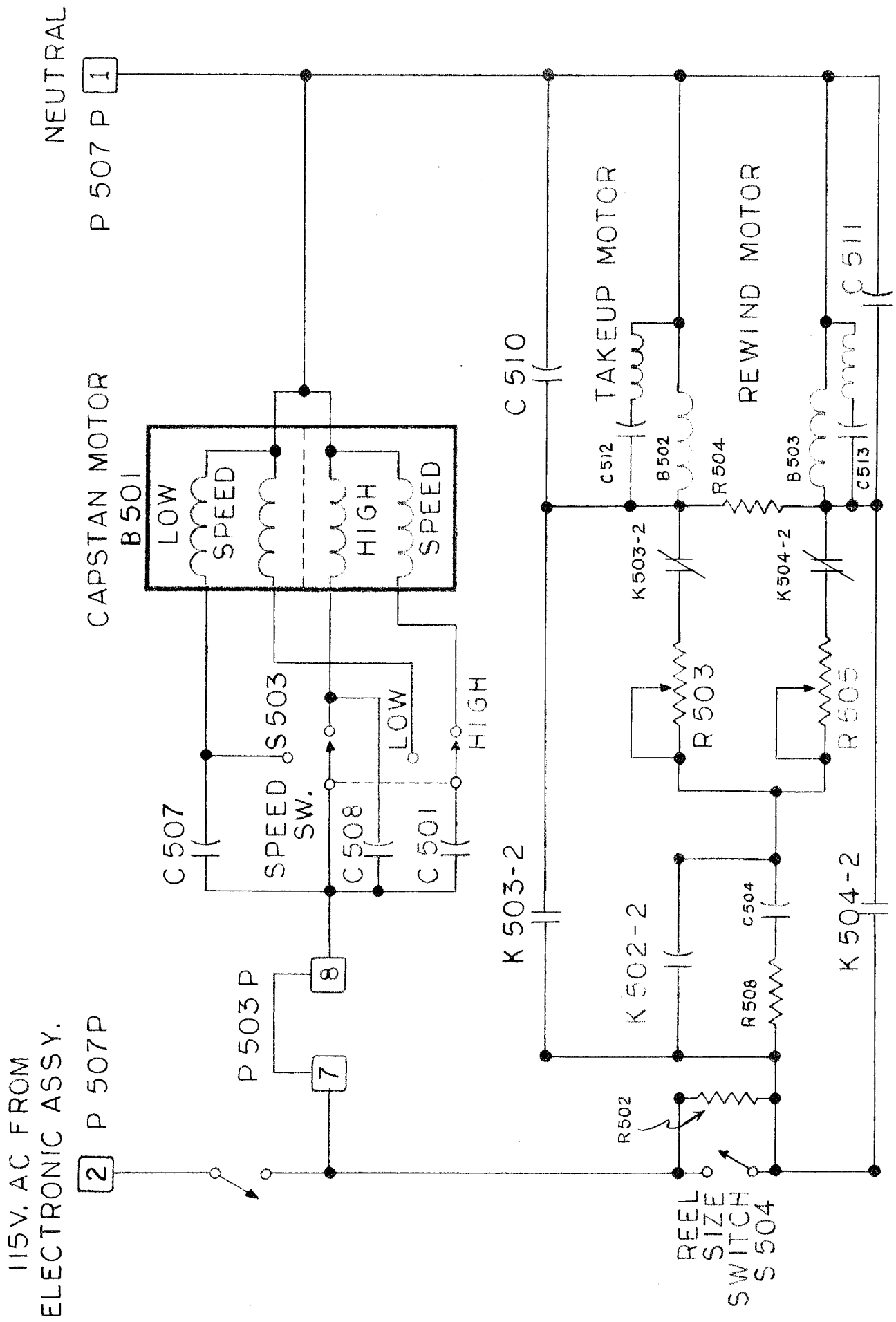

NOTE: —|— = RELAY CONTACTS, NORMALLY OPEN. —|/— = RELAY CONT., NORM. CLOSED. —|— = CAPACITOR.

SERVICE BULLETIN

AMPEX

AUDIO PRODUCTS DIVISION • AMPEX PROFESSIONAL PRODUCTS COMPANY

DATE October 20, 1959
MODEL General
BULLETIN NO. 9-03
PAGE NO. 1 of 11

BRAKES, BRAKE BAND REPLACEMENT AND TENSION ADJUSTMENTS

Part I - Old Brake Assembly

Two different designs of Brake Assemblies have been used on the Model 300 and Model 350 Series Recorders. The earlier design, which was discontinued on production models of the 300 Series and 3200 Series during 1956 and the 350 Series on August 1, 1959, is shown in Figure I.

This design used graphited felt brake bands and one brake tension spring which is adjustable to maintain proper brake tension settings.

After long usage, the graphited-felt brake lining will begin to glaze, and the brakes may exhibit some tendency to grab. This condition may be relieved by periodic readjustment of brake tensions and the cleaning of the brake drum.

The brake drum may show some spots of material on its surface which are normal and of no great harm to the function of the brakes. These deposits of material on the drum are particles of graphite and dust gathered by the static charge developed by the rotating drum. Clean the surface with solvent or, if necessary, with #240 grit sandpaper.

Brake linings may be reconditioned in place by the following procedure: Mix one level tablespoon of graphite with 8 ozs. of carbon tetrachloride. Apply to the brake linings with an oil can. (Be sure the can is free of all traces of oil). After re-graphiting, the turntable motors should be run for ten minutes with the brakes on in order to wear in the graphite. This can be accomplished either by disconnecting the brake solenoids temporarily, or by removing one of the clevis pins in the brake linkage to prevent the brakes from being released when the solenoids are energized.

If the brake linings are too badly worn to respond to this reconditioning procedure or if the brake band is broken, it is necessary to replace the brake band assemblies which are available in sets of two. Order Kit #7970-01.

REMOVAL PROCEDURE

The following procedure for removal and installation of the brake band assembly should be done with care. Slight misadjustment of the band when installing could cause future breakage and excessive wear.

Removal of the complete torque motor assembly from the tape transport is sometimes necessary or desired depending on the accessibility to the brake housing assembly into which the brake band is to be installed.

- Step 1: With a 7/16" socket wrench remove the four mounting screws and washers at the motor mounting plate, carefully holding the motor with one hand to prevent it from falling. The turntable will remain attached to the motor assembly.
- Step 2: Take the motor to a convenient work area.
- Step 3: Unhook the brake tension spring from the brake lever.
- Step 4: Remove the two screws holding the motor capacitor to the solenoid bracket. (On some models the capacitor is mounted on the side of the motor which makes this step unnecessary). Let capacitor hang free of housing. Replace one of the screws temporarily to keep the solenoid bracket tight on the housing for future adjustments.
- Step 5: Remove the screws that hold the brake housing to the motor, noting the positioning of the housing, washers, and spacers, and remove the entire housing.
- Step 6: Remove the two socket-head screws that hold the brake band to the housing at Point "A". Note that three clamping elements are involved: The clamp, and two spring-steel leaves.
- Step 7: Loosen, do not remove, the two screws that hold the other end of the brake band to the #330 link by inserting a socket-head screw key (i.e., an Allen wrench) between the two brake solenoid links. The old brake band can now be removed from the link and brake housing.

INSTALLATION PROCEDURE

Before installing the new brake band, it should be pressed flat between two boards in a vise in order to compress the felt lining. If this is not done, the lining will be too thick to permit free rotation of the brake drum after installation, and will result in dragging brakes and improper brake differential. Once the band is installed, the felt will no longer swell, as it does relatively quickly when the bands are not bent in their normal curve.

The new band should be handled carefully. Contact with the felt lining and fingers should be kept to a minimum as the natural oil from the skin will affect the friction characteristics of the prepared felt surface.

The spring steel band should be free of any foreign material on the side opposite the felt lining. Wiping the spring steel with a soft cloth impregnated with a non-oil base solvent should be sufficient to remove any foreign material.

It is also a good procedure to clean the inside of the brake housing and the brake drum surface (note fourth paragraph, page 1) with a non-oil base solvent before installing the new band.

- Step A: Slide the new brake band assembly into the opening on the side of the housing. Follow the curvature of the housing, making sure the band is not kinked at any time.
- Step B: Slide band far enough around the inside of the housing so that slotted end of band can be slipped back into the #330 link. Tighten one Allen screw at the link to keep band in place until later adjustment is made.
- Step C: Line up opposite end of band with holes at Point "A". Connect band, following the sequence shown in the drawing. The two leaves are intended to relieve all possible strain on the band at this point. Tighten Allen screws to the #329 clamp, making sure the edges of the band, band leaves and clamp are even.

Step D: Push the solenoid plunger down by hand until it bottoms in the solenoid. Loosen the Allen screw in the #330 link and adjust the depth of insertion of the slotted brake band between the link and clamp so that the band will be expanded firmly and evenly against the inner wall of the housing. Tighten Allen screws.

CAUTION: If the band is set too far forward in the link, it will buckle slightly when the solenoid plunger is bottomed. If this condition continued to exist, the spring steel band would eventually break at the point of buckling.

Step E: Remount the brake housing assembly on the motor. (Be sure to install the spacers).

Step F: Reinstall brake tension spring.

Step G: Push the solenoid plunger down by hand until it bottoms; then release, noting the distance the plunger returns due to the tension spring. The distance the solenoid plunger travels is directly proportional to the clearance between the brake band felt and the brake drum when the solenoid plunger is bottomed in the solenoid.

The clearance between the brake band felt and brake drum when the solenoid plunger is bottomed can be adjusted to a minimum by moving the brake housing assembly slightly on the motor mounting studs in the direction desired. This can be accomplished by tapping lightly on the base of the brake housing with a plastic hammer.

The best conditions exist for long life of the band when the plunger travel and brake band clearance is kept to a minimum. This results in less movement of the brake band at Point "A" and less tendency for the brake band to buckle at the #330 link.

Step H: Remount capacitor to bracket, if previously removed. (Be sure the smaller of the two screws goes into the solenoid assembly).

Step I: Remount torque motor assembly to transport.

Step J: Run the brakes in for ten minutes, as described in the reconditioning procedure, before adjusting brake tensions.

Part II

The new brake assembly shown in Figure II is currently used on production Models 300, duplicator and 351 series recorders.

This design uses a Raybestos brake band with two adjustment points to maintain proper brake tension settings. To replace the older brake assemblies with the newer version simply order by Ampex catalog number below:

<u>TAPE WIDTH</u>	<u>ASSEMBLY</u>	<u>CATALOG NO.</u>
1/4 inch	Takeup	17327-1
1/4 inch	Rewind	17327-2
1/2 inch	Takeup	17327-3
1/2 inch	Rewind	17327-4
1 inch	Takeup	17327-5
1 inch	Rewind	17327-6

The assembly is shipped from the factory with all adjustments set for correct performance.

In the course of wear in normal service, or in the event of brake band failure, readjustments and replacement of the brake band may be necessary.

Periodic readjustments of brake tensions, after long usage, is necessary to maintain proper brake tensions. If brake tensions cannot be maintained, it may be necessary to recondition the bands in the following procedure: Remove the brake housing assembly in the same manner called out in the brake band replacement. Clean the brake drum surface with a non oil base solvent. Clean the Raybestos brake band surface by sanding lightly with a #240 grit sandpaper. Replace the brake housing assembly and adjust tensions.

If the brake linings are too badly worn to respond to this reconditioning procedure or if the band is broken, it is necessary to replace the brake band assemblies which are available in sets of two. Order #17612-01.

RAYBESTOS BRAKE BAND REPLACEMENT

Removal of the complete torque motor assembly from the tape transport is sometimes necessary or desired depending on the accessibility to the brake housing assembly into which the brake band is to be installed.

Brake bands may be replaced without removing motor from tape transport on rackmount machines and deleting the first two steps.

- Step 1: With a 7/16 socket wrench remove the four mounting screws and washers at the motor mounting plate, carefully holding the motor with one hand to prevent it from falling.
- Step 2: Take motor to a convenient work area.
- Step 3: Unhook the brake tension spring from the brake lever.
- Step 4: Remove the two screws holding the capacitor to the solenoid bracket. (On some models the capacitor is mounted on the side of the motor which makes this step unnecessary). Let capacitor hang free of brake housing. Replace one of the screws temporarily to keep the solenoid bracket tight on the housing.
- Step 5: Disconnect the solenoid wires at knife disconnects.
- Step 6: Remove the screws that hold the brake housing to the motor, noting the position of the washers and spacers and remove the entire housing.
- Step 7: Loosen (do not remove) the two cap screws at the end of the brake band next to the solenoid. (Point A).
- Step 8: Remove the two cap screws (at Point B) holding one end of the brake band between the brake lever spring and the housing using a 5/16" Allen wrench.
- Step 9: The brake band may now be removed taking caution not to lose the band leaf on the solenoid side. There is only one band leaf per assembly.

Before installing the new brake band, clean the inside of the brake housing and the brake drum surface with a non-oil base solvent.

- Step 10: Position the new brake band through the hole in the housing. Follow the curvature of the housing and place between the clamp and link at Point B. Replace the two cap screws and tighten.
- Step 11: Insert the other end of the band between the band link and clamp at Point A, making certain that small band leaf is also positioned at this point on inside of band next to the clamp. Do not tighten the two cap screws at this time.
- Step 12: Replace the brake housing assembly on the motor, making certain that the spacers, housing, lock washers and the screws are replaced in that order and tighten the screws.
- Step 13: Push the solenoid plunger in by hand until it bottoms. Adjust the depth of insertion of the brake band between the link and clamp at Point A so that there is no buckling of the band and so that the brake drum rotates freely with no drag. Then tighten the two cap screws.
- CAUTION: If the band is set too far forward in the link it will buckle when the solenoid plunger is bottomed by hand. If this condition continued to exist the band would eventually break at the point of buckling.
- Step 14: Interconnect the wires at the knife disconnects and replace the capacitor to the bracket with the two screws removed in Step 4.
- Step 15: Hook the brake spring to the brake lever.
- Step 16: Replace the motor assembly, if removed in Step 1, tightening the four screws securely.
- Step 17: Run the torque motors for approximately ten minutes. Energize and de-energize the brake solenoid several times to seat the brake bands against the drums.
- Step 18: Adjust the brake tensions to the correct settings as called for in "Brake tension adjustments".

BRAKE TENSION ADJUSTMENT

Smooth brake operation is of primary importance in maintaining proper tape tension while stopping the tape. Since the hold-back tension, supplied by the trailing turntable motor torque, is lost as soon as the Stop button is pressed, the maintenance of tape tension then becomes a function of brake operation. The fundamental design consideration in the brake system is that the braking force acting on the turntable from which the tape is being pulled (the trailing turntable) in any of the modes of operation must always exceed the braking force acting on the turntable taking up the tape (the leading turntable) in order to prevent the throwing of tape loops.

Brake tension is adjusted with no power applied to the machine. Note that the old style brakes, Figure I, have only one spring tension adjustment which is for the high side. The low side tension is a ratio of the high side setting. On the new style brake assembly, Figure II, there are two adjustment points. One for the high side tension and one for the low side tension. The procedure is, as follows:

- A. Place an empty 10-1/2 inch NARTB reel on the tape supply turntable.
- B. Tie a loop at each end of a piece of string about thirty inches long.
- C. Attach one loop to the tape anchor on the reel hub. Wind the string on by turning the reel clockwise by hand.
- D. Attach the loop in the free end of the string to a 0-32 oz. spring scale, and pull. (The turntable will rotate counterclockwise). Take a reading only when the turntable is in steady motion, as the force required to overcome the static friction will produce an excessively high initial reading.
- E. Adjust the brakes for scale readings listed below.
- F. Now wind the string on the hub by rotating the reel counterclockwise; pull, and take a reading. (The turntable will rotate clockwise.) The reading should be approximately as listed below.

- G. Repeat the entire process on the takeup turntable. Note that the direction of most resistance is opposite that of the supply turntable.

If small EIA reels or hubs only are used, the brakes will not necessarily stop without some slack forming when fast winding onto the small reel or hub. This is because with normal brake settings, the inertia of the reel that is taking up the tape serves to tension the tape, and if the brakes are set tight enough to stop a small reel without slack, the tension on the tape will be excessive when using the regular reel.

SPRING SCALE READING

Tape Width	Direction of Most Resistance Supply Counterclockwise Takeup Clockwise	Direction of Least Resistance Supply Clockwise Takeup Counterclockwise
1/4 inch	15 to 16 ounces	2:1 ratio \pm 1 ounce in accordance with the High Side
1/2 inch	19 to 20 ounces	2.5:1 ratio \pm ounce, etc.
1 inch	22 to 24 ounces	3:1 ratio \pm ounce, etc.

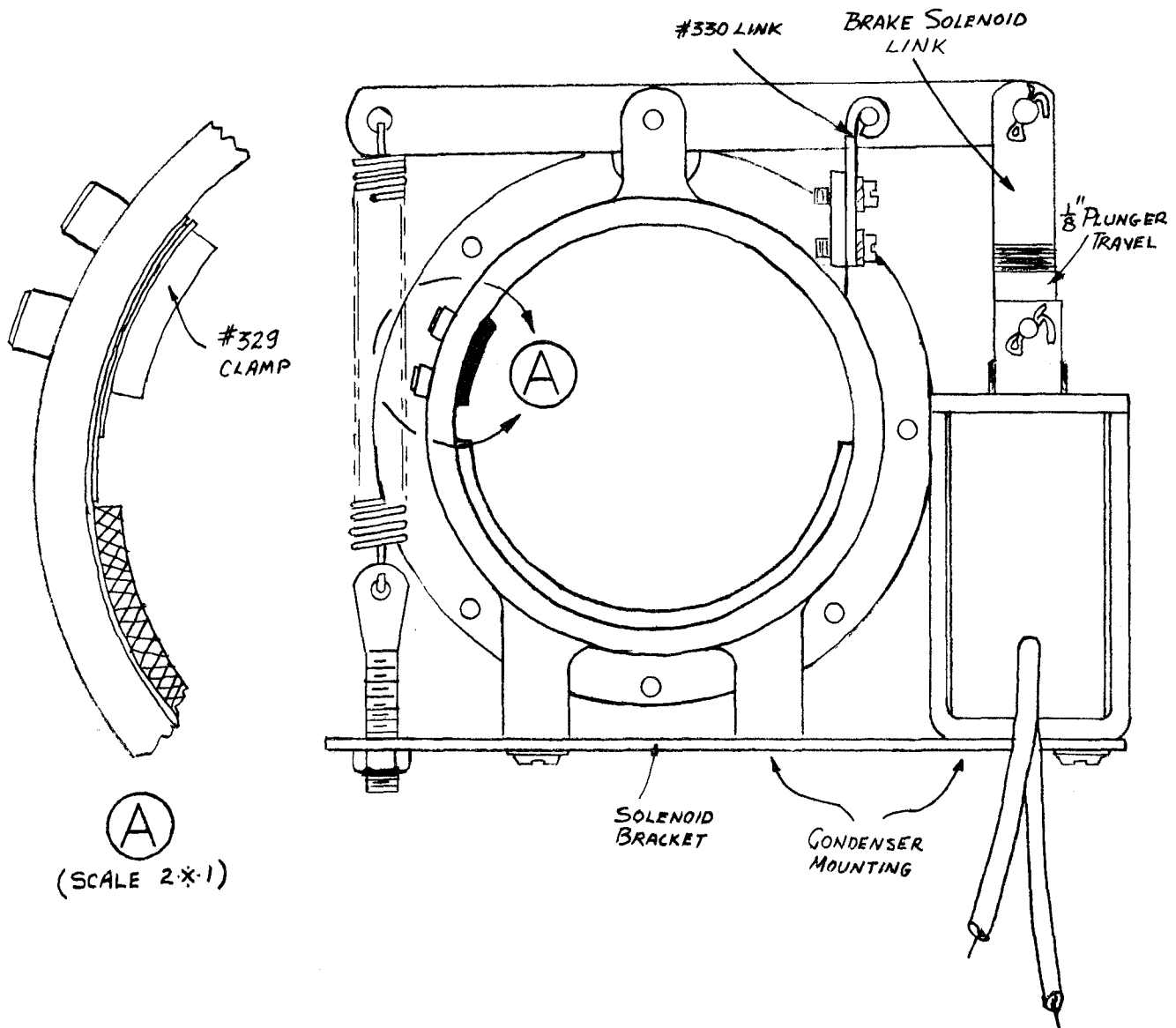
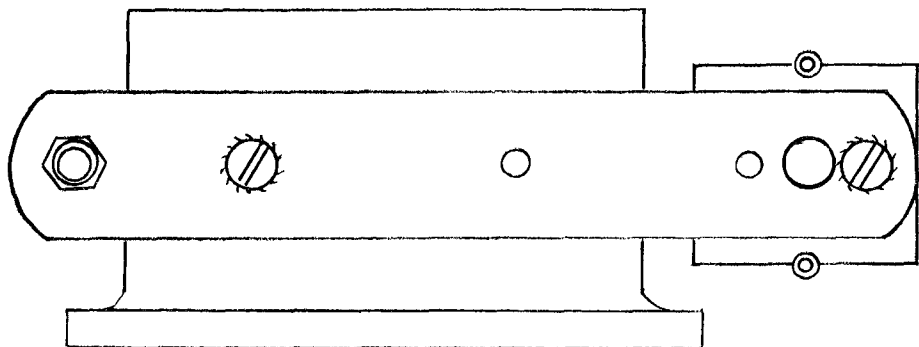

FIG. 1



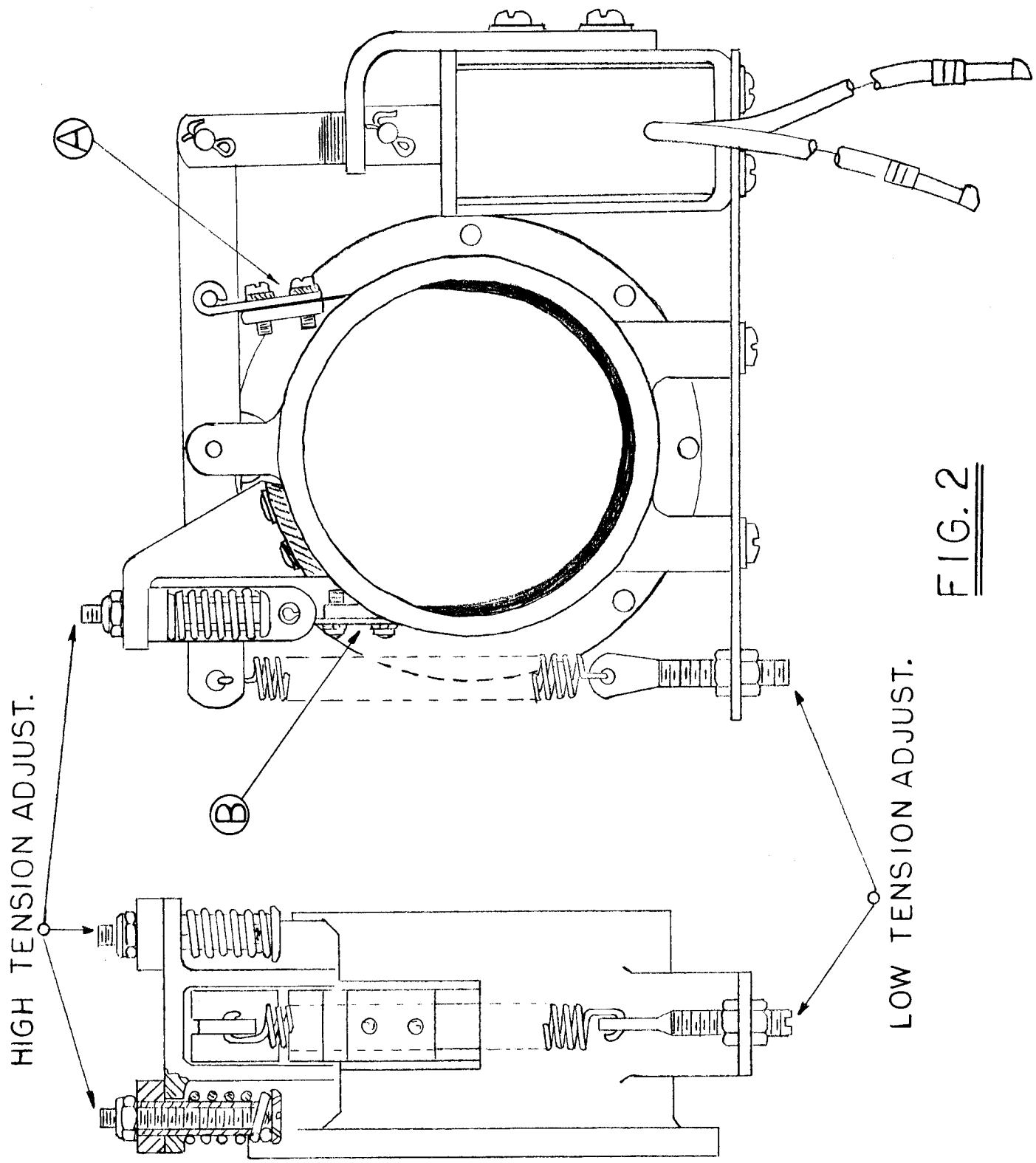

FIG. 2

SERVICE BULLETIN

AMPEX

AUDIO PRODUCTS DIVISION • AMPEX PROFESSIONAL PRODUCTS COMPANY

DATE	6/13/60
MODEL	350/351
BULLETIN NO.	0-04
PAGE NO.	1 of 1

TRANSPORT CAPACITOR CLAMP

Vibration or shock has occasionally caused broken leads of capacitor C502 in the transport relay control box.

Installation of a Mallery TH-23 clamp (Ampex #301-011) to secure the capacitor will prevent such an occurrence.

Remove the control box from the transport. Drill a 1/8" hole in the control box end plate above J501S, centered between the sides and 5/8" from the flanged edge.

Place clamp on capacitor and secure through mounting hole with a 4-40 x 1/4" screw (Ampex #475-006) and a 4-40 nut (Ampex #492-008).

This modification has been accomplished on recorders bearing serial numbers above 6500.

SERVICE BULLETIN

AMPEX

AUDIO PRODUCTS DIVISION • AMPEX PROFESSIONAL PRODUCTS COMPANY

DATE 9 December 1959
MODEL General
BULLETIN NO. 9-05
PAGE NO. 1 of 1

TURNTABLE MOTOR ASSEMBLY

A review of turntable motor assemblies indicates that it is possible and desirable to standardize the turntable motor assembly, catalog number 6768-00, for direct replacement on all Model 300, 3200, 3300, 350 and 351 series transports.

The 6768-00 turntable motor assembly is now a direct replacement for the following previously listed turntable motor assemblies.

<u>Model</u>	<u>Obsolete Spare Assembly</u>
300	2458-00; 6768-01; 6768-02
3200-3300	2458-00; 6768-01; 6768-02
350/351	7558-00 and 6768-01

The 6768-00 assembly is provided complete with motor, brake drum, turntable, mounting flange and capacitor.

SERVICE BULLETIN

AMPEX

AUDIO PRODUCTS DIVISION • AMPEX PROFESSIONAL PRODUCTS COMPANY

DATE	2/24/60
MODEL	351
BULLETIN NO.	0-02
PAGE NO.	1 of 1

TAKEUP TENSION ARM ADJUSTMENT

The Model 351 transport is factory adjusted to handle tape at maximum efficiency in the type mounting it is to be used. When changing from horizontal mount to vertical mount, some change in adjustment may be necessary.

The takeup tension arm return spring plus the weight of the guide in vertical mount position may overcome the trailing motor holdback tension and drift to the horizontal position, cutting off the transport power.

This can be corrected by removing the cap on the takeup tension arm assembly and moving the spring counter-clockwise from its hooked position on the roll pin stud to the roll pin stud located 180° opposite it. The spring can be further moved 360° counterclockwise from its original position, if moving 180° is not sufficient to overcome the tension.

Care should be used so that sufficient tension remains to allow actuating the micro-switch.

The reverse process may be necessary if a vertically mounted transport is to be used in horizontal position. In this case, the spring should be moved clockwise to provide sufficient tension to actuate the safety switch.

SERVICE BULLETIN

AMPEX

AUDIO PRODUCTS DIVISION • AMPEX PROFESSIONAL PRODUCTS COMPANY

DATE	4/18/60
MODEL	351
BULLETIN NO.	0-01
PAGE NO.	1 of 1

TAKEUP AND SUPPLY TENSIONS

New values for the takeup and supply tensions on the Model 351 which will provide improved tape handling characteristics have recently been determined by our engineering department.

Refer to page 5-10 in the instruction manual, under "Take-up and Supply (Rewind) Tension". The procedures outlined for checking and adjusting tension are correct. However, in Step 11 change "between 6 and 7-1/2 ounces" to read "between 5-1/2 to 6 ounces". In Step 12, change "should indicate 2 - 2-1/2 ounces" to read "should indicate 1 - 1-1/2 ounces".

It is recommended that 351 equipment produced prior to April 15, 1960 (approximately serial number 6100 and below) be checked and re-adjusted to the new tensions to ensure best performance.