

**AMPEX**

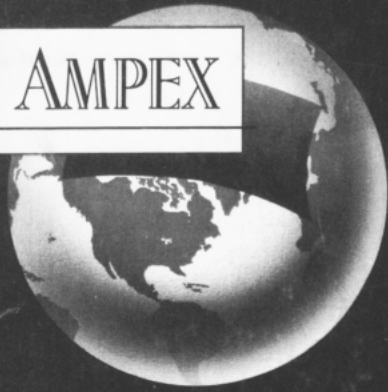

**AMPEX PROFESSIONAL PRODUCTS COMPANY**

**BASIC CONCEPTS OF  
MAGNETIC TAPE RECORDING**

**Fundamental Theory And Design Considerations  
For Professional Audio Equipment**

**ENGINEERING DEPARTMENT PUBLICATION**

**934 CHARTER STREET • REDWOOD CITY, CALIFORNIA**

## TABLE OF CONTENTS

FOREWORD .....	1
GENERAL .....	1
WHY MAGNETIC TAPE? .....	2
BASIC COMPONENTS OF A MAGNETIC TAPE RECORDER .....	2
Magnetic Tape .....	2
Heads .....	3
<i>Recording</i> .....	3
<i>Erasing</i> .....	4
<i>Reproducing</i> .....	4
Tape Transport — General .....	5
<i>Supply and Takeup System</i> .....	5
<i>The Drive System</i> .....	5
<i>Head-to-Tape Contact</i> .....	5
<i>Tape Tracking</i> .....	5
Tape Transport — Detailed Discussion .....	5
<i>Flutter and Wow</i> .....	5
<i>Drive Requirements</i> .....	6
<i>Supply and Takeup Assemblies</i> .....	6
<i>Reel Idlers</i> .....	7
<i>Mounting Plates</i> .....	7
<i>Tape Guiding</i> .....	7
<i>Takeup Tension Arm</i> .....	7
<i>Operational Requirements</i> .....	8
Electronic Circuits .....	8
<i>Record Amplifier</i> .....	9
<i>A-C Bias</i> .....	9
<i>Reproduce Amplifier</i> .....	10
FACTORS IN DETERMINING IMPORTANT OPERATING CHARACTERISTICS .....	10
General .....	10
Distortion .....	11
Signal-To-Noise Ratio .....	11
<i>Track Width</i> .....	11
<i>Track Spacing</i> .....	12
<i>Equalization</i> .....	12
FREQUENCY RESPONSE .....	13
Head-To-Tape Contact .....	13
High Frequency Response .....	13
<i>Gap Effect</i> .....	13
<i>Head Resonance</i> .....	14
Low Frequency Response .....	14
Additional Factors For Multi-Channel Recording .....	15
<i>Phasing Between Channels</i> .....	15
<i>Crosstalk Rejection</i> .....	15
Head Assemblies .....	15
BASIC ADJUSTMENTS ON MAGNETIC TAPE RECORDERS .....	15
Head Azimuth Adjustment .....	16
Level Adjustments .....	16
Equalization Adjustment .....	16
Record Bias Adjustment .....	16
Tape Tension .....	16
Braking Adjustment .....	17
Demagnetization .....	17
Noise Balance .....	17
Cleaning .....	17
CONCLUSION .....	18
BIBLIOGRAPHY .....	18

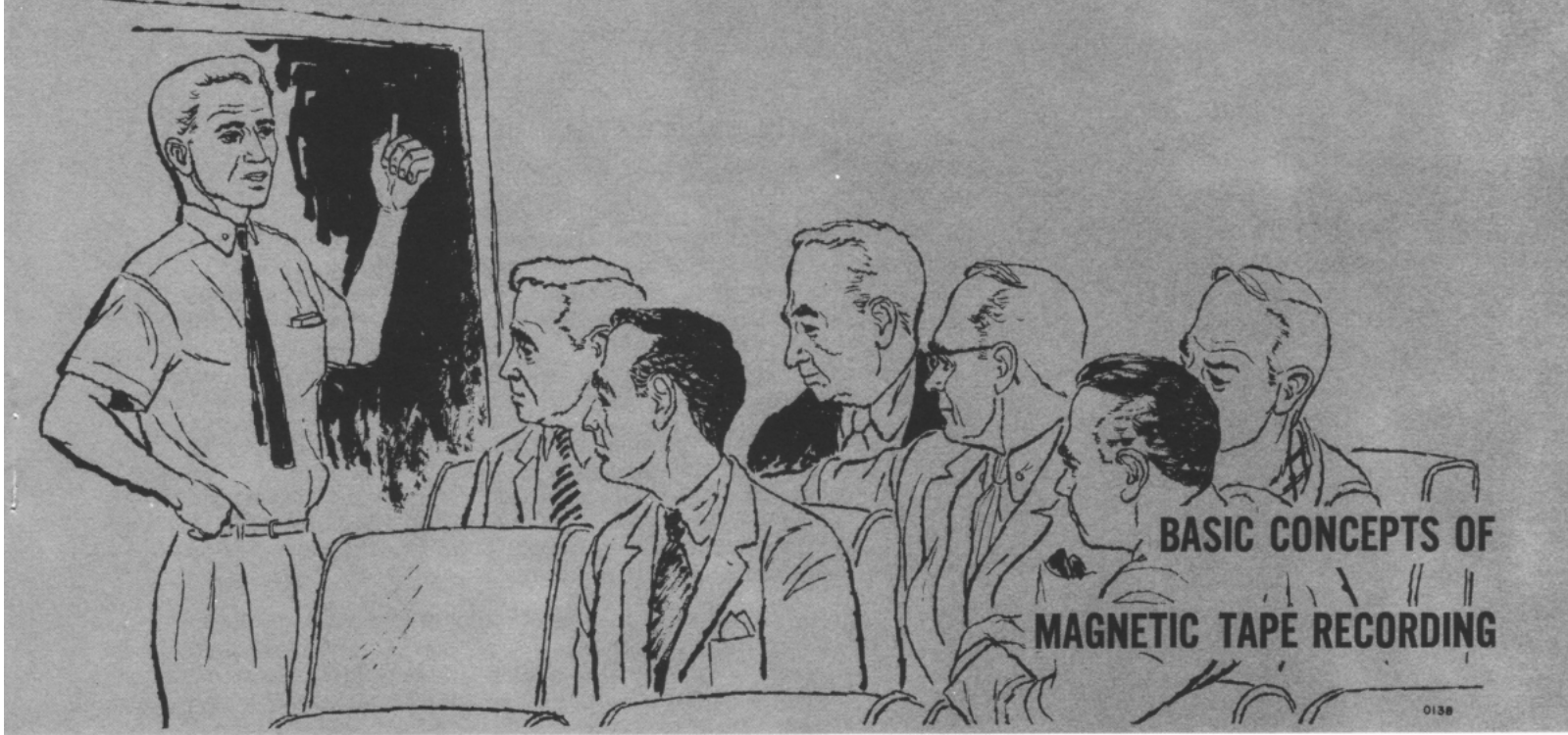

## Fundamental Theory And Design Considerations For Professional Audio Equipment

Copyright 1960 by AMPEX CORPORATION

### FOREWORD

This discussion is intended only as an introduction to magnetic tape recording, an attempt to explain the fundamental theory in the simplest possible terms. As in any such endeavor there will no doubt be areas which are over-simplified, and in these instances it is requested that you remember the basic objective stated above.

Information presented here was obtained from various sources by the Technical Publication Section of AMPEX PROFESSIONAL PRODUCTS Co., Audio Division. Included in the Appendix is a bibliography which lists the published works used. Other sources utilized were AMPEX Engineering Reports (not available for general distribution), and personal interviews with AMPEX engineering personnel.

### GENERAL

Let it be understood to start with that you are not going to be bored by the long, drawn out, discussion of the history of magnetic recording which is the seemingly inevitable preface to any attempts to explain the basic theory of this process. But it seems pertinent to point out that the first patent on a magnetic recording device was issued some 60 years ago, and it was originally anticipated that its main use would be in the telephone and telegraph industries. So magnetic sound is not a recent innovation.

It is also interesting to note that probably the first magnetic recorder to use tape (steel tape, that is)

instead of wire as the recording medium was developed for a motion picture application. About 1920 a British producer named Louis Blattner acquired patent rights to manufacture magnetic recording equipment for use in the entertainment field. His machine, the "Blattnerphone," supplied synchronous sound for some of the first talking pictures in England.



*Typical professional quality recorder/reproducer in portable case. Ampex Model PR-10-2 fits either a portable carrying case or will mount without modification in a normal 19-inch rack.*

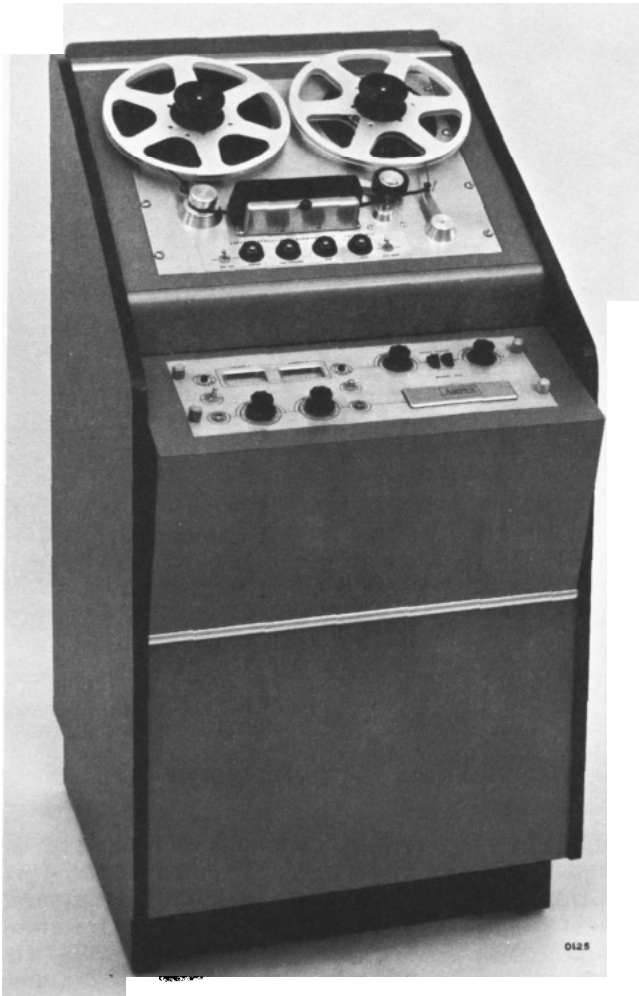

A console mounted Ampex Model 354, two channel recorder/reproducer.

### WHY MAGNETIC TAPE?

There are many advantages to recording on today's high quality magnetic tape, using professional grade equipment. No other device can offer comparable fidelity of reproduction. Tape provides the convenience of immediate playback without processing, and the economy of being able to erase and re-record. It furnishes a large storage capacity in a minimum space. Technically one of its greatest attributes is a gradual overload characteristic which exacts a minimum penalty for slightly incorrect record level adjustments. Audio recordings can be stored indefinitely or replayed thousands of times with no deterioration of signal. And tape still is the only practical means of recording professional quality stereophonic sound; though two track discs are used extensively in home music systems, the original master recordings for those discs are made on tape.

Magnetic recording has made possible the presentation of three, four, and six channel sound in the motion picture theater. In this instance, of course, the magnetic material is striped on film rather than on the usual plastic backing.

## BASIC COMPONENTS OF A MAGNETIC TAPE RECORDER

### Magnetic Tape

Modern magnetic tape consists of a plastic backing, on which is deposited a layer of magnetic material consisting of iron oxide particles suspended in a synthetic resin binder. The iron oxide material is the actual magnetization medium, and since it is in the form of minute particles the recording process must depend on the size, shape, orientation, and uniform distribution of these particles on the tape.

Manufacturers have greatly increased the quality of magnetic tape over the past few years, but it remains true that variations in magnetization within individual wavelengths will occur. The magnitude of these variations will depend on the factors noted in the preceding paragraph.

A random packing density of the oxide particles will impose a random variation of amplitude of a recorded signal, which will appear as noise in the reproduced output. In high frequency applications, where only a surface layer of the tape is involved, the signal-to-noise ratio will be particularly affected.

If the backing which supports the medium is not uniform in thickness, it will create variations in the deposit of oxide coating at the base. In low frequency work the under layers assume importance and such variation in coating will, again, be reproduced as noise.

Any lack of uniformity in the coating implies a lack of perfect flatness at the tape surface, so separation of the tape from the heads will vary. This will affect the output capabilities (see Frequency Response). Suitable polishing of the tape after manufacture will reduce this variation, and some manufacturers are now pre-polishing their professional grade tape. This polishing also minimizes head wear for equipment that will continually run new tape, such as duplicating systems for the commercial recording industry.

Tape width variations can also cause trouble when

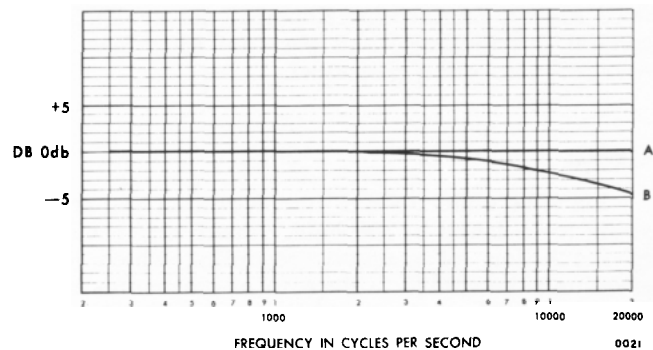

The difference in response between polished (curve A) and unpolished (curve B) tape is indicated on this graph. Readings were taken using new tape from the manufacturer (B) and again after mechanical polishing by running the oxidized surfaces against each other (A).

the clearance on guides is limited to minimum figures to obtain extremely accurate guiding. If the width of the tape then exceeds tolerances, the guides will bow the tape, and it will again be lifted from contact with the heads. Slitting the tape must, therefore, be rigidly controlled.

The binder material must be wear resistant. This is not primarily a matter of ensuring the durability of the recording, but rather is to minimize oxide deposits on components in the tape threading path (see Cleaning). Of course, if the binder breaks down sufficiently to cause signal drop-outs it would affect the durability, but this will be encountered normally only after prolonged use at high tape speeds not usually employed in audio work.

There are several considerations concerning the iron oxide particles which affect tape characteristics. These include the size and shape of the particles, and their physical orientation so that the axes of easy magnetization are longitudinal to the direction of recording.

In addition to all the above, tape must be strong enough to withstand the stresses it will undergo in normal operation, and pliable enough to follow the required turns in the tape threading path.

Recognizing that the quality of magnetic recording is today limited by the properties of the tape, not the equipment, AMPEX recently entered the tape manufacturing field. It is felt that the association of AMPEX and its subsidiary — Orr Industries Co. — will result in definite improvements in the art of magnetic recording.

### Heads

No assembly in a magnetic recording system is more important than the heads, which convert the electrical current to a magnetizing force during the recording operation, then reconvert that magnetism to an electrical current during the reproduce mode. Professional quality equipment employs three separ-

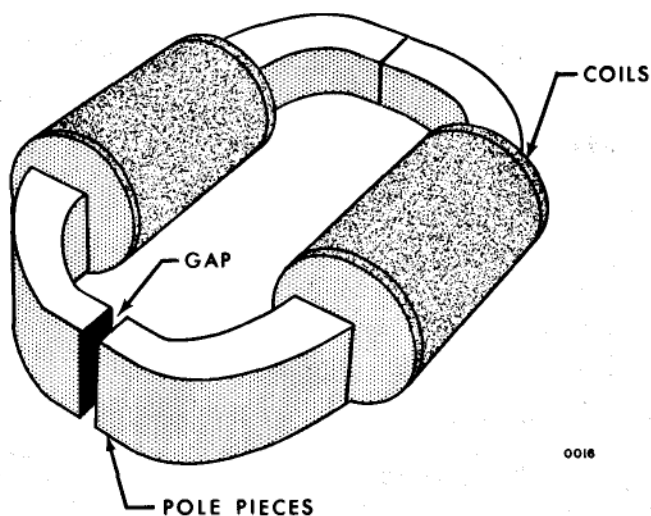

Construction of a typical magnetic head.

ate heads — erase, record, and reproduce — each especially designed to perform its specific function.

### Recording

The operation of the record head is essentially the same as that of an electro-magnet. If we insert a core of permeable material within a coil of wire, then run a direct current through that wire, we can set up an intense magnetic field that will attract any nearby material that is capable of being magnetized. If instead of the direct current, we use an alternating current, we would first attract then repel that material (at a rate controlled by the frequency of our a-c) until it assumed a position that was neutral in respect to the alternating field.

In a magnetic recording head the core is shaped like an incomplete ring — the discontinuity forms the head "gap" — which is inserted within a coil of wire. When the signal to be recorded is converted to an electric current and passed through the coil, a strong magnetic field is created across the gap. If we now pass our magnetic tape across the gap, the iron oxide particles in the tape will be magnetized in a pattern which is a function of the instantaneous magnitude and polarity of the original signal. Understand here that these particles do not physically move, but are simply magnetized by the flux at the head gap so that each individual particle contributes to an overall magnetic pattern.

The wavelength of the signal recorded on the tape depends upon how far the tape moves during each complete alternation of the signal current. For example, if we were recording 60 cycles at 15 inches per second, each cycle would be recorded on a 0.25 inch segment of the tape; if our frequency were 6000 cycles and our tape speed  $7\frac{1}{2}$  inches per second, each cycle would be recorded on a 0.00125 inch segment of the tape. Such computations may be continued for any frequency at any tape speed by simply dividing the tape speed (in inches per second) by the frequency (in cycles per second).

This brings up a point that sometimes confuses individuals accustomed to considering wavelength and frequency as being practically synonymous terms — that a certain wavelength can denote only one frequency or vice versa. This cannot hold true on any device which employs a moving medium to store the information. For example, say we record a frequency of 10,000 cycles at a tape speed of 15 ips. If we reproduce that tape at the same speed we will re-create our original signal; but if we reproduce the tape at  $7\frac{1}{2}$  ips the same wavelength on the tape will result in a signal of only 5,000 cps, if our reproduce speed is  $3\frac{3}{4}$  ips our signal will be 2,500 cps. Similarly, if we record 10,000 cps at 15 ips the wavelength is 1.5 mils, if we record the same signal at  $7\frac{1}{2}$  ips the wavelength is .75 mil, at  $3\frac{3}{4}$  ips the wavelength is .375 mil. Thus, wavelength may vary for a constant frequency and frequency may vary for a constant wavelength, dependent on the speed of our medium.



In magnetic recording such differentiation is important. Certain losses — such as amplifier response, self-resonance of head windings, eddy current losses in head cores, etc. — are frequency-dependent losses. Others — reproduce gap losses, head-to-tape spacing losses, tape thickness losses, etc. — are wavelength-dependent losses.

### Erasing

Our major purposes in erasing are to obliterate any prior recording and to leave the tape quiet, so that it may be used again and again for different programs. Permanent magnets will do the erasing job, but it is difficult to prevent these devices from magnetizing the tape in one direction — a single pole on the magnet would magnetize the tape to saturation, and a high noise level would result in the subsequent recording. The common practice, therefore, is to subject the tape to an a-c field which gradually increases to a maximum magnitude, then gradually decreases to zero.

The erase head functions exactly the same as the record head, but it is constructed with a relatively large gap — which allows the flux to leak out over a relatively large longitudinal area in the tape path. We send a high frequency a-c signal to the head. As a point on the tape approaches the gap, the alternating magnetic field gets stronger and stronger until a maximum magnitude is reached directly at the gap. Then as the point recedes from the gap, toward the record head, the field grows weaker and weaker until it disappears. Remember here that we are talking of relative distances, and the erasing field will disappear before our point on the tape approaches the record head.



*Magnetic reproducing equipment in the motion picture theater. Ampex installation along the far wall (at Warner Theater, New York City) provides six channel stereophonic sound.*

### Reproducing

Although the reproduce head is constructed almost the same as the record head, it functions more like an electric generator. When we move a conductor through a magnetic field, as we do in a generator, we induce in that conductor a voltage whose amplitude and polarity are functions of the magnitude and direction of the magnetic field. We can, of course, achieve the same results by passing the magnetic field across a stationary conductor, as the only requisite is that the conductor must cut the lines of force. (Note here that, assuming a constant field, the amplitude of the induced voltage is dependent upon the speed with which the conductor cuts the lines of force.)

Similarly, when we move the recorded tape past the gap in a reproduce head, the magnetic flux on the moving tape will induce a voltage in the head coil. This induced voltage will be proportional to the number of turns of wire on the head coil, the permeability of the core material, and the time rate of change of the magnetic flux.

Assuming a constant tape speed across the head, the last factor means that the output of a given reproduce head will increase directly with frequency (as frequency rises there is a greater rate of change of flux across the head gap for a given tape speed).

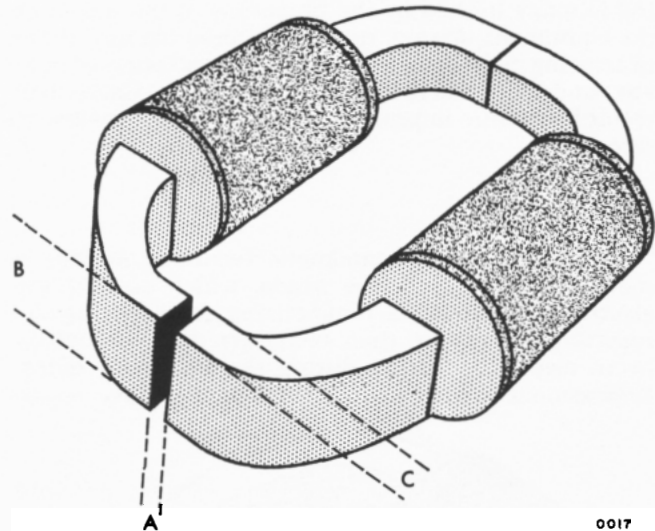

*Head gap terminology used in this discussion (A) gap length (B) gap width (C) gap depth.*

In reproducing information from a recorded tape, one important factor is the dimension of the reproduce head gap. We have seen that the magnetic flux on the moving tape induces a voltage in the head coil; but what actually occurs here is a little more complex than that simple statement implies.

Actually, the flux must travel to the coil through each branch of the head core (forced into that path by the high reluctance of the gap) and must result in a voltage differential across the coil if a current is to be created. Therefore, an instantaneous difference in the magnitude of the moving flux must exist across

the head gap. This means that the gap must always intercept less than one complete wavelength of the signal recorded on the tape (see High Frequency Response). However, if the gap is too small the flux will not be forced through the core to the coil, and signal level will be reduced. An optimum design, tailored to specific requirements of frequency response and level is thus necessary.

### *Tape Transport — General*

The function of the tape transport is to move the tape accurately across the heads at a precisely constant rate of speed. We can consider that all tape transports consist basically of three major divisions — first a tape supply system, then a tape drive system, and finally a tape takeup system. These divisions can be likened to two reservoirs with a pumping station between them that removes material from one reservoir and adds it to the other. Most professional quality equipment employs three motors (or their equivalents), one each for the supply system, drive system, and takeup system; however, if weight or volume is important (such as in portable machines) high quality results can be obtained by using one motor to drive the tape and employing mechanical coupling to the supply and takeup turntables.

### **Supply and Takeup Systems**

Usually, the tape supply and tape takeup systems can be considered as identical assemblies, with the only probable differences being in the brake configuration and the connection to the power source. Torque motors (or their equivalent) are used to drive the turntables directly. These motors are connected to rotate in opposite directions when power is applied — the supply motor opposing and the takeup motor supporting the normal direction of tape motion.

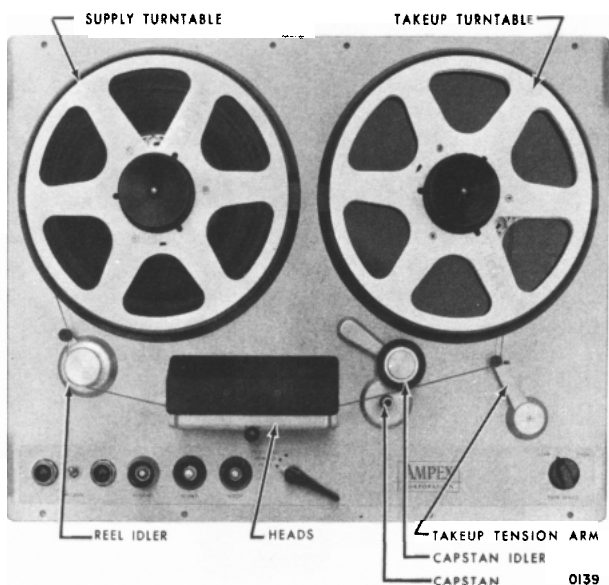

*Typical professional quality tape transport showing the top components on an Ampex Model 300.*

In the record and reproduce modes these motors act simply to maintain proper tape tension and have no influence on tape motion, which is controlled entirely by the drive system. During this operation the supply motor imparts tension by opposing tape motion, while the takeup motor attempts to turn slightly faster than necessary to wind in the tape from the drive system.

In the fast winding modes of tape travel, the reel motors *do* control the tape motion. Here one motor is operated under full power and the other with reduced power; the greater torque of the motor under full power overcomes the lesser opposing torque and tape is simply pulled from one reel to the other, again under correct tension.

### **The Drive System**

The drive system utilizes a synchronous motor coupled either directly or through a pulley arrangement to the capstan. The circumference of the capstan and its rotational velocity determine the speed of the tape in the record and reproduce modes.

While tape *speed* is a function only of the capstan, tape *motion* in record and reproduce is instigated when a capstan idler (sometimes called a pressure roller) clamps the tape between the capstan and itself, thus providing a surface against which the capstan can drive the tape. The capstan idler is normally coupled to a solenoid, which in turn is actuated by the play switch. This arrangement allows a "fast start" condition in which the capstan motor is operating whenever power is applied to the equipment, and tape can be quickly brought to full speed whenever the play switch is pressed.

### **Head-to-Tape Contact**

Good head-to-tape contact and proper placement of the tape on the heads is extremely important. An inherent characteristic of magnetic tape recording is that the effective recording or reproducing of a signal on magnetic tape deteriorates with any spacing between the tape and heads. Thus, any loss in good head-to-tape contact will result in impaired performance — in recording there will be signal drop outs, in reproducing there will be a loss in frequency response.

### **Tape Tracking**

If the tape does not track correctly across the heads, frequency response, phasing, and level will be affected. Two guides will thus bridge the head assembly. In professional quality equipment the positioning of the guides will ensure good head-to-tape contact and the accurate placement of the tape.

### *Tape Transport — Detailed Discussion\**

### **Flutter and Wow**

Flutter (or wow) is the amount of deviation from a mean frequency, caused by anything in the system that will affect tape motion.

\*From "Multichannel Recording For Mastering Purposes", Journal of the A.E.S., October 1960.

For instance, to consider an exaggerated example, if we were reproducing a sustained 1000-cycle tone at a tape speed of 7½ inches per second and that speed suddenly dropped to 6 inches per second our tone would be reduced to 800 cycles; then as normal speed was again attained the tone would return to 1,000 cps.

Differentiating between flutter and wow has historically been difficult, but speaking generally we can consider that flutter consists of components about 6 or 7 cycles per second, with wow components falling below that figure. (Normal flutter will extend to approximately 250 cps, but tape scrape flutter is usually about 3500 cps.) Flutter and wow can result from anything that affects tape motion; although the drive system of a transport is most commonly blamed it is not always at fault.

#### Drive Requirements

Designing a drive system usually entails a compromise between low flutter requirements and the amount of money we can expect in return. There are ways and means of producing transports that exhibit extremely low flutter; the accomplishment, however, is accompanied by a high price. These ultra precision drives are usually employed only in certain instrumentation and data type recorders, with the cost precluding their use in other than very special applications.

**CAPSTAN ASSEMBLY** — First, the capstan shaft. A small, round shaft seems quite simple and harmless, but it can be a real troublemaker. It must be round within small tolerances (0.2 mil) and mounted in its bearing it must exhibit minimum “run-out” (again, 0.2 mil) at the tape contact point. The shaft must be corrosion resistant, and sufficiently hard to withstand wearing.

The diameter of the capstan should be large enough to hold tape slippage and creep to a minimum, with a compromise normally necessary between the diameter and the speed of the shaft. For a given tape speed an increase in diameter demands a decrease in rotational speed, which in turn requires more flywheel.

We generally will use as much flywheel as the drive motor can handle while maintaining sync; this is simply a matter of filtering any cogging of the drive motor, or other irregularities. As the mass of the flywheel increases, its efficiency in damping out high frequency irregularities improves, but it might start to accentuate low frequency disturbances. If this occurs we must provide some damping arrangement — for example, silicone coupling between the shaft and flywheel.

**DRIVE MOTOR** — The drive motor must be of the synchronous type in order to maintain the necessary speed accuracy. Hysteresis synchronous motors are usually employed rather than salient pole (reluctance) types, although the latter is less expensive and provides as good results insofar as flutter is concerned. The reason for this preference is that the

hysteresis motor will sync a greater mass and thus can handle a larger flywheel.

#### Supply and Takeup Assemblies

When motors are used in the supply and takeup assembly they are usually of the induction type, with high resistance rotors. Reel motors must be as free from cogging as possible, because cogging in the hold back system has been responsible for many flutter problems that have been blamed on the drive assembly. It would be nice if we could discover a reel motor whose torque would change with the tape diameter on the reel, thus providing a constant tape tension throughout the reel of tape. (Many constant tension devices have been used in the past, but those designed for audio equipment have not been too successful.)

AMPEX is now using eddy current clutches on the turntables of some of the latest recorders. These devices provide completely cog-free operation (dependent only on a well-filtered d-c supply voltage) and thus result in improved flutter and wow. There are no commutators or slip rings, therefore no replacement problem, and *no rf interference* is generated. Faster start times are realized because of the small mass, and an associated low inertia, when compared to the rotor of a conventional torque motor.

The brakes, generally associated with the turntable assemblies, can be either of the mechanical or dynamic type. At AMPEX, the feeling has always been that mechanical brakes are superior. With mechanical brakes, a self-limiting — or at least a non-energizing — configuration should be used. Energizing type brakes that are not limiting will give quite different braking forces as the coefficient of friction changes with variations in temperature and humidity.

Another consideration in designing the brake system is the differential. This differential, as applied to magnetic tape recorders, means the difference in braking force that exists between the two directions of turntable rotation — with the greater force always acting on the trailing turntable (in respect to tape motion). The differential is expressed as a ratio,

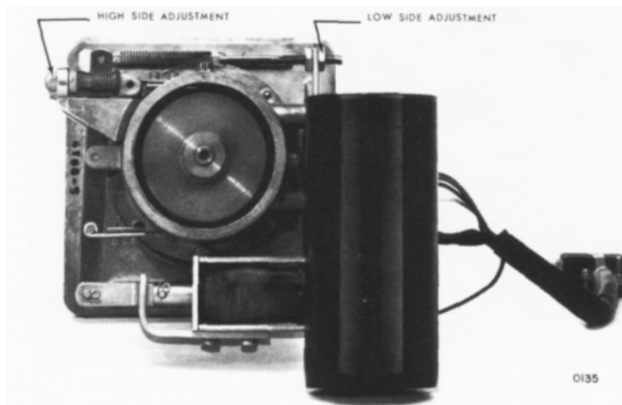

*Typical mechanical brake assembly as used by Ampex, showing the two adjustment points.*



which is chosen to prevent excessive tape slack being thrown in the stopping process from the normal or fast winding modes of operation.

### Reel Idlers

The main purpose of the reel idler is to isolate the heads from the disturbances originating in the supply motor, by tape scraping against the reel flanges, by splices as they leave the reel, or by tape layers slipping as the reel unwinds. (This last effect may be quite prevalent if tape is wound so fast that air is trapped between the layers, thereby producing a very loose pack.)

While the reel idler minimizes such disturbances, we must use care or we will create more flutter than we eliminate. Reel idlers should have minimum run-out, bearings must be selected for low noise and smoothness of operation, and flywheels must be dynamically balanced to close limits. And the diameter of the idler and the tape wrap around it must ensure positive coupling between the tape and the idler. As with the capstan flywheel, a damping arrangement might be necessary.

### Mounting Plates

Mounting plates should be sufficiently rigid to maintain a natural resonance above 300 cps — or notably higher than the 60 and 120 cps exciting frequencies which emit from torque motors and drive motors. This rigidity is most important in the area surrounding the reel idler, heads and capstan; any flexure in this area will cause flutter.

Of course, another reason for a rigid mounting plate is to hold alignment between the various components that control the tracking of the tape. This is more important on 1/2-inch tape or 1-inch tape than it is with 1/4-inch.

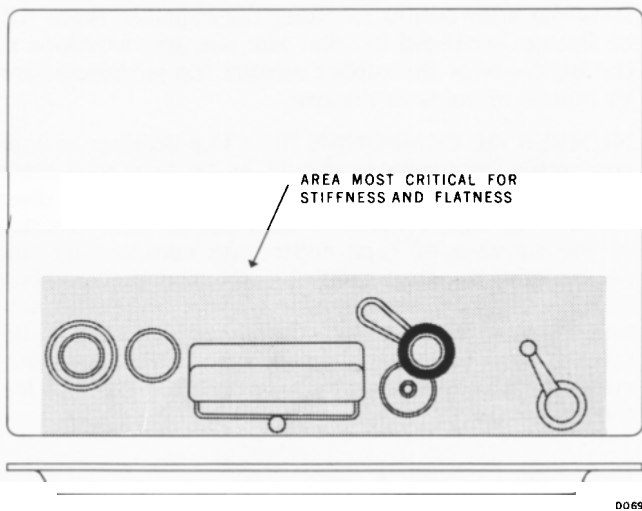

*The most critical area of the transport for rigidity and flatness is shown by the shading.*

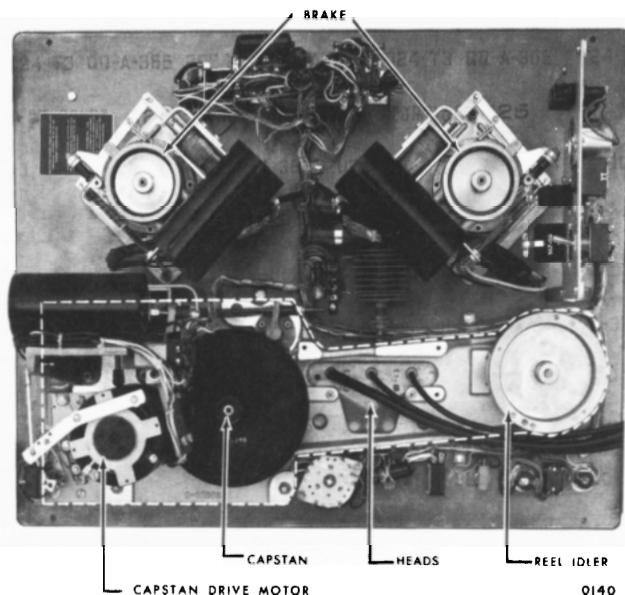

*Back view of a typical professional tape transport. Dashed line indicates heavy mounting casting employed in area where rigid construction is critical. (Ampex Model 300.)*

### Tape Guiding

Next to flutter, our most difficult problem of tape transport design is the tape guiding. Certain design rules must be followed. All components in the tape threading path must be kept in accurate alignment — this means maintaining exacting tolerances on the perpendicularity and flatness of all such components (turntables, reel idlers, heads, capstans, etc.)

The capstan idler must hit the capstan squarely, or the tape will be diverted up or down. Tape guides, either rotary or fixed, should not be too small in diameter, and guide widths must be held to close tolerances — normally not more than 2 mils over tape width and preferably less. (Tape itself is slit to a tolerance of 0 to 6 mils under the nominal dimension.)

Tape guiding problems are multiplied when we use thin base tapes. This is caused by the loss of stiffness at the edge and because we must use lower tensions with this type tape.

Incidentally, if we have a well designed tape transport that has received good maintenance and suddenly have tracking problems, we can suspect the tape itself. A quick check on the tape is to stretch out an approximate three foot length beside a straight-edge. If it does not line up with the straightedge it has been poorly slitted, or stored on a poorly wound reel, and the best thing to do is dispose of it — quickly!

### Takeup Tension Arm

The main duty of the takeup tension arm is to act as a tape storage loop and thus takeup any tape slack that occurs during starting. It also usually incorporates a safety switch that automatically stops oper-

ation when tape is exhausted from the reel, or if the tape breaks.

#### Operational Requirements

We must provide adequate torque for the fast forward and rewind modes, with the actual torque requirements varying with the tape width. But we must bear in mind that excessive torque might result in our exceeding the elastic limits of the magnetic tape, and result in breaking or deforming the tape.

The tape must be stopped without damage. The elastic limit of the tape again determines our maximum braking force. Since a minimum brake differential must be maintained, this factor also determines our lower braking limit.

We must also have reasonable start and stop times.

Therefore, we must provide optimum torque and braking force, adequate for fast winding and acceptable start and stop times, but which will not exceed the elastic strength of our medium. Typical values for a 1/2-inch tape equipment would be 35-40 ounce-inches of torque, with a maximum braking force of approximately 30 ounces, measured on a 2 1/4-inch radius (N.A.B. reel hub).

**TAPE THREADING** — From the human engineering standpoint, tape threading paths using the wrap-around principle are superior to those utilizing a "drop-through-the-slot" type. The utmost efficiency in threading tape would be provided by a transport that had a simple wrap-around path from supply reel to takeup reel, with no necessity for threading behind idlers, guides, etc. Unfortunately this perfection is impossible of achievement — although it can be approached — because of the necessity for threading the tape between the capstan and the capstan idler. Of course, a transport employing a system of self-



*Magnetic equipment in the recording industry. Ampex Model 300-3 installed at United Recording Studios, Hollywood.*

threading, with reels compatible with those now existing, offers a definite improvement. The threading path can then be engineered for optimum performance of the equipment, disregarding the human equation.

**TAPE WRAP** — The amount of wrap-around the heads should be held to a minimum, because the build-up of tape tension will increase with the degree of head wrap. Depending on the flexibility of the tape and the geometry of the head, it is possible that a large tape wrap will result in the tape bowing out at the apex of the head and losing contact at the gap. A wrap of 4 to 6 degrees on each side of the head gap has proved quite satisfactory.

Large tape wraps (in degrees) around small diameters should be avoided. This is not only a case of holding tension build-up to a minimum. While there are no qualitative data available *it has been proved that sharp bends around small diameters result in measurable losses of recorded high frequencies during the first three or four playbacks.*

Tape wrap around the reel idler must be sufficient to ensure a good, solid coupling between the tape and the idler. On AMPEX machines operating at 60 and 120 ips, it has been necessary to groove the tape contacting area of the idler pulley so that the air film is dispelled and good coupling is ensured. The effect of insufficient coupling can be seen in the fast forward or rewind modes of a standard recorder; the air film picked up by the fast moving tape acts as a cushion and the idler barely turns. The air film can be advantageous if we wish to operate in a fast winding mode without mechanically lifting the tape from the heads, but it proves quite troublesome at times (especially when we are trying to get a good pack during a fast winding mode using 1-inch tape).

**DRIVE LAYOUT** — The heads, capstan and capstan idler should be arranged so that the tape from the heads first contacts the capstan not the idler. In those layouts where the tape from the playback head contacts the idler before reaching the capstan, there will be flutter — caused by idler run-out, by variations in the hardness of the rubber around the periphery, and by bumps or voids in the tire.

**NUMBER OF COMPONENTS** — The number of tape contacting components should be held to a minimum, because every additional part means more build-up in tape tension. This build-up is a function of the number of tape contacting components, the degree of tape wrap around each, and their surface roughness. The geometry of the layout must eliminate unnecessary guide posts, idlers, etc. Tension build-up can also be reduced by mounting the necessary components on ball bearings, or on other types of low torque bearings.

#### *Electronic Circuits*

There are three main electronic circuits which usually are provided — a record amplifier, a bias and erase oscillator, and a reproduce preamplifier. These will normally be quite conventional audio



Typical two channel electronic assembly. Ampex Model PR-10-2 professional recorder/reproducer.

circuits, except for certain minor modifications made necessary by the special application. (Note here that such necessary items as line amplifiers, power amplifiers, loudspeakers, microphones, mixers, etc., are not considered part of the magnetic recorder.)

### Record Amplifier

The function of the record amplifier is to present to the record head a signal current of proper amplitude for the recording process. The record head is essentially an inductance whose impedance will vary directly with frequency. The magnetizing force is directly related to the amount of current which flows in the head coil, so high frequencies would suffer if the rising impedance of the head coil at the higher frequency were allowed to decrease the current flow appreciably. Therefore, the output circuit of the amplifier will present a relatively high resistance in respect to the head coil, which will now have a minor effect on the complete circuit; a virtually constant current condition is thus maintained regardless of the frequency involved.

In order to further ensure proper recording of high frequencies, the record amplifier also contains a pre-emphasis circuit which essentially provides more amplification as frequency rises. Because the reproduce curve has been standardized, the pre-emphasis circuit is adjustable to reproduce a flat overall response when the reproduce amplifier is set on the standard curve.

### A-C Bias

The normal magnetization curve of any ferromagnetic material is extremely non-linear, with the slope near the point of origin practically zero. Theoretically we should be able to record in this region with no correction (it is sufficiently linear) by maintaining signal amplitude at a sufficiently low level. However, such a recorded signal would be so small that the signal-to-noise ratio would be unacceptable.

By using carefully chosen values of d-c bias we can utilize the approximately linear portion of the curve in recording a limited range of alternating signal amplitudes. But lower basic noise and more linear results over a greater range of signal levels can be accomplished by using an a-c bias voltage. The frequency of this a-c bias is not critical, but it should be

several times that of the highest signal frequency (in AMPEX audio equipment the bias frequency is normally 100 kc).

Fundamentally, biasing with an a-c field is similar to a long-known method of achieving an "ideal" (or "anhysteretic") magnetization. In this method, an alternating field of high amplitude is superimposed on an unidirectional field, then the amplitude of the alternating field is gradually reduced to zero. The result is a remnant magnetization that is a linear function of the unidirectional field. The maximum amplitude of the alternating field is unimportant as long as it exceeds a certain level, and the final state of magnetization will depend only on the value of the unidirectional field when the alternating field strength falls below a certain level.

If we assume that while a point on the moving

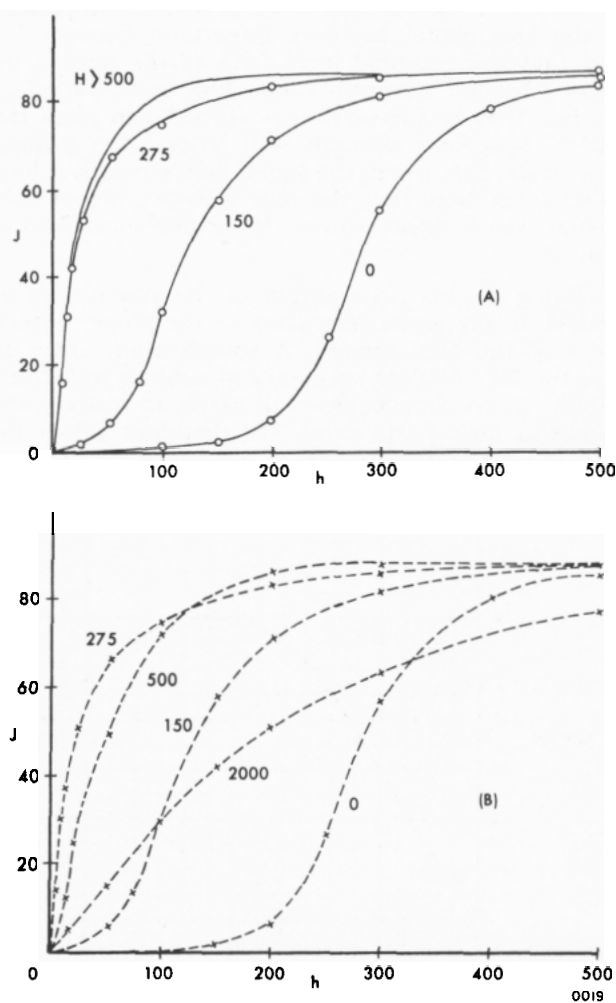

Anhyysteretic intensity of magnetization (J) is plotted against the unidirectional field strength (h) for various amplitudes of a-c bias in this chart. In (A) the bias field was reduced while holding the unidirectional field constant. In (B) both fields were reduced simultaneously. Note in (B) that increasing the bias field beyond a certain value decreases the intensity of magnetization.

tape is within the gap of the record head it is subjected to a high frequency alternating field that is maximum at the center of the gap and decreases smoothly to zero on either side, plus a signal field that looks like an unidirectional field for that instant, we can see the degree of similarity that exists between the ideal magnetization method and an a-c biased magnetic recording.

As usual, however, there is one major area of difference. In the ideal method, the unidirectional field strength is held constant while the alternating field decreases to zero. In magnetic recording both fields reduce at the same rate as the point on the tape leaves the record gap, and the remnant magnetization on the tape will be determined by the signal strength when the bias reduces to the critical level. As a consequence, the remanent magnetization in recording, while linear, is always less than could be achieved by the ideal method. Another result is that the amplitude of the bias signal becomes important, because we find that the recorded level falls as the bias is increased beyond a certain value. This is explained by the fact that an excessive bias current can place the critical bias field strength well beyond the trailing edge of the gap, where the signal field strength is low. (Remember here that the only effective signal field is that which exists where the critical bias field is located.)

Using a-c bias, the output of the system can be peaked at any given frequency by the proper adjustment of the bias current. A complication arises in that the bias current necessary to achieve maximum output at low frequencies will result in a decreased output at high frequencies. We therefore adjust the bias at a given wavelength of the signal on the tape (see Record Bias Adjustment).

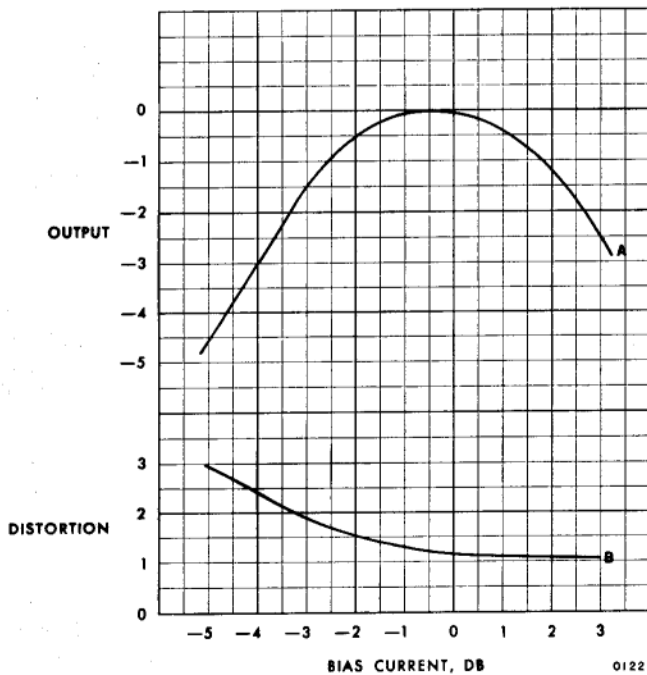

Typical output (A) and distortion (B) vs. bias current. Readings taken at 1000 cps at 15 ips.

## Reproduce Amplifier

Preliminary amplification of the signal induced in the reproduce head is accomplished in the reproduce (or "playback") preamplifier. You will recall that the output of a reproduce head rises directly with frequency. This increasing output is at an approximate six db per octave rate (a very technical way of saying that the voltage output doubles each time the frequency doubles) so an opposite characteristic is required to obtain a flat overall frequency response.

An integrating amplifier, which attenuates rising frequencies at a 6 db per octave rate, is thus necessary for the reproduce function. The NAB standard curve incorporates this integrating amplifier modified by a rising frequency characteristic (or "post emphasis"). This post emphasis is achieved by an r-c circuit with a time constant dictated by tape speed and set by standards — for example, NAB standards for 7½ or 15 ips calls for a 50 microsecond time constant, which places the +3 db point at 3,180 cycles.

## FACTORS IN DETERMINING IMPORTANT OPERATING CHARACTERISTICS

### General

The most important operating characteristic in any sound storage device are low distortion, high signal-to-noise, good frequency response, and low flutter and wow. The last was thoroughly covered in

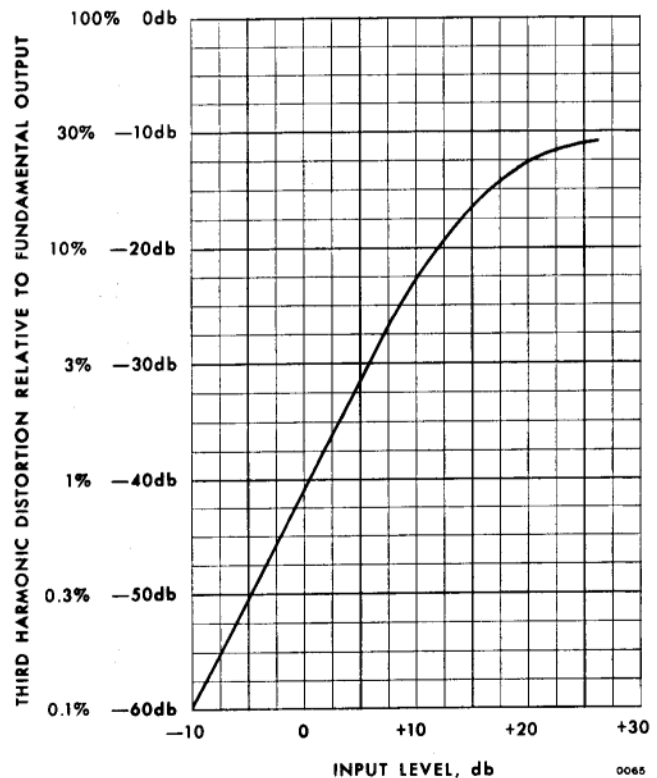

Typical third harmonic distortion vs. input level at 400 cps, measured at 15 ips. Distortion is plotted on a db scale to obtain a logarithmic function in linear steps.

the discussion of the tape transport, so we will treat the first three in this portion and then follow with additional factors encountered in stereophonic recording.

### Distortion

Distortion in magnetic recording is a function of both the bias adjustment and the recording level. We have already seen the effect of the bias voltage near the point of zero magnetization on the tape (see Electronic Circuits) so in this we will cover only the effect of the recording level.

To achieve a maximum signal-to-noise ratio, we wish to record at the highest possible signal level. But as we increase our recording level we will eventually reach the point where any further increase has little effect in magnetizing the tape. We have "saturated" the medium, and any additional current in the record head will simply give distortion.

In distortion caused by over-recording, the odd harmonics will stand out, with the third harmonic predominating. Our prevailing standards define the *normal recording level* as the point where there is a 1% third harmonic content of the signal, and the *maximum recording level* as the point where there is a 3% third harmonic content.

Such a standard implies that the professional user will have equipment to adjust his recorder to meet these distortion specifications. It is rare that wave analyzers or distortion meters are available, therefore the calibration is usually made by using a standard tape (see Basic Adjustments).

### Signal-To-Noise Ratio

Many factors complicate the signal-to-noise problem, some of them entirely beyond any control of the manufacturer of magnetic tape recorders.

First is the tendency of both studios and "hi-fi" fans to reproduce music at a greater volume than that of the original source. This, of course, also increases the audible noise level.

Then there is the fact that the average loudspeaker is deficient in response, and directional at high frequencies. The deficient response sometimes results in the user increasing the high frequency energy electrically (with an equalizing circuit) during the recording process. This extra high frequency energy increases the problems that exist in high frequency overloading. The directional pattern at high frequencies means that, if the average high frequency energy throughout the room is to equal the energy at lower frequencies, the high frequency energy *on the axis of the speaker* is higher than that

of the middle frequencies, and the audible noise level is increased. The noise coming from a small area is also more noticeable than if it emanated from a large source.

But probably the major complication is that the human ear is most sensitive to noise in the 1 to 6 kc area, and the noise below 100 cps must be very great before it is objectionable. The usual meter indication consists largely of the low frequency component of noise, which is inaudible; it is for this reason that a recorder which tests quieter than another on our normal measuring devices sometimes sounds noisier when we actually listen to it. (Significant noise measurements, therefore, can be achieved only by using a weighting network with an inverse response to that of the human ear.)

But these are things we cannot control. What can we do to get the best signal-to-noise ratio?

Our major limiting factor today is the magnetic

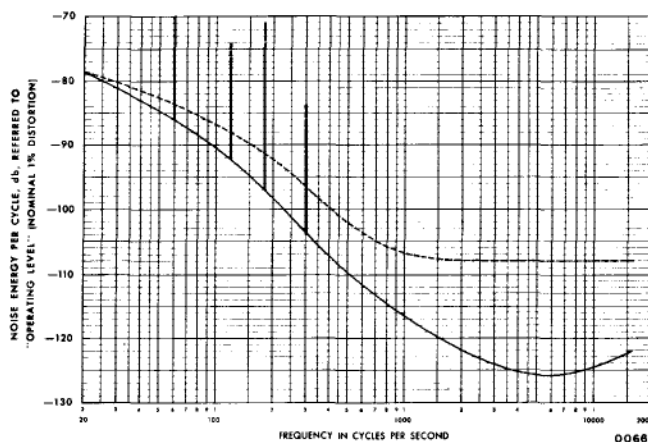

*Typical spectral noise density of the system (dash line) and the equipment (solid line). Readings taken on an Ampex full track Model 351 at 15 ips. Noise spikes occur at 60, 120, 180, and 300 cps on both curves (that at 60 cps rises to -55 db and -57.5 db respectively). System noise taken with tape in motion, equipment noise with tape stopped.*

tape. Our "system noise" (which includes the tape) is from 8 to 10 db higher than our "equipment noise". A theoretical study has shown that an improvement in the noise characteristic of the tape should be possible by decreasing the size of the oxide particles, and tape manufacturers are experimenting with this theory.

Assuming a given tape noise, we are mainly concerned with track width, track spacing (in multi-channel equipment), tape speed, and equalization.

### Track Width

Where the maximum signal-to-noise ratio is necessary, wide tracks are desirable, but there are certain limitations. Economically, the amount of tape used, and therefore the cost, increases roughly in propor-



tion to the track width. Technically, beyond a certain track width it becomes difficult to maintain accurate azimuth alignment.

If the signal-to-noise ratio is determined by the medium itself, (the tape noise is at least 8 to 10 db above the equipment noise) then the signal-to-noise of the system is proportional to the square root of the track width.

So, just how wide should the track be? As the track width increases, closer and closer mechanical tolerances must be held to maintain the same linear alignment accuracy, which determines the azimuth alignment and therefore the high frequency response and stability. Experience has shown that, for 15 ips recording speeds, it is practical to maintain azimuth alignment for track widths up to 250 mils. (For lower speeds, say at 7½ ips, it is difficult to maintain azimuth alignment for tracks wider than 100 mils.)

Remembering our practical economic considerations, we can put three 100 mil tracks, separated by 85 mils, on ½-inch tape (or six tracks on 1-inch tape). The three track, ½-inch, equipment is widely used in recording master tapes, and has been accepted as the best compromise between tape utilization and track width. Different configurations of track width and spacing, with the relative signal-to-noise ratios of each, are shown in an accompanying illustration.

### Track Spacing

Two crosstalk effects are known to occur: At long wavelengths magnetic coupling occurs in reproduce between the signal recorded on one track and the

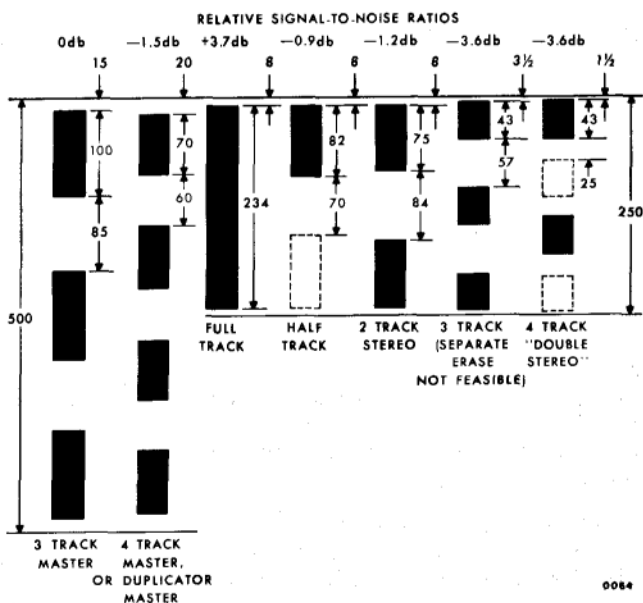

Normal record and reproduce head configurations used by Ampex, with relative signal-to-noise ratios in respect to the 100 mil track width. Dimension of six and eight track heads on 1-inch tape are the same as those shown for the three and four tracks on ½-inch tape. All dimensions are in mils.

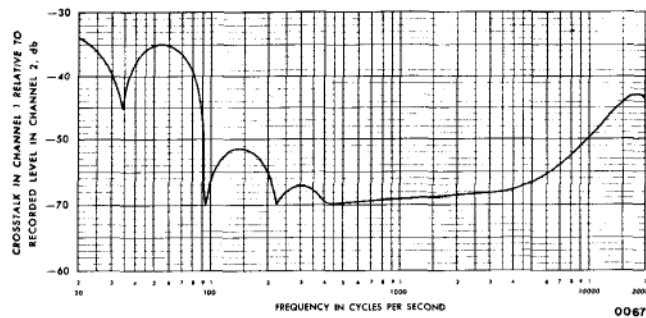

Typical crosstalk vs. frequency curve on adjacent channels of an Ampex three channel Model 300. Channel 2 was recording at normal operating level and the record head of Channel 1 was connected. Normal bias and NAB equalization were used.

reproduce head of the other track. At high frequencies, the mutual inductance and capacitance between the two record heads causes the signal from one record head to be present in the other record head, and therefore to get recorded on that other track. Therefore spacing and shielding between cores is important in both the record and reproduce heads. Obviously the closer together the tracks the more coupling exists (assuming the same shielding). With good shielding, an 85 mil track-to-track spacing (used for Ampex ¼-inch two track, and ½-inch three track recorders) is a good compromise — more spacing to reduce crosstalk is unnecessary and would waste space, but any less would result in the increased crosstalk becoming audible above the noise.

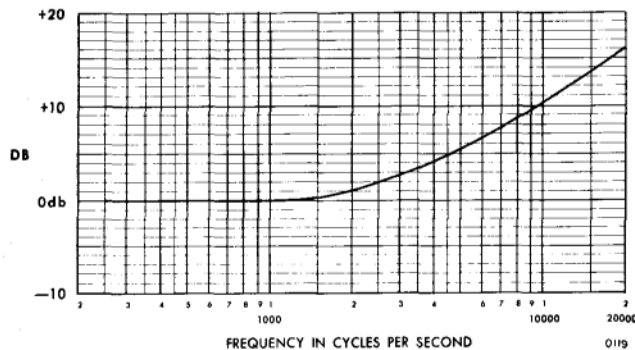

Standard NAB post-emphasis curve for 15 ips.

### Equalization

Reproduce equalization has been standardized for some time, with the curve in general use specified by the NAB (standard equalization in Europe usually follows the CCIR curve). Any pre-emphasis curve, therefore, must be tailored to the standard reproduce curve.

It is the feeling at AMPLEX that the present NAB specifications are convenient curves, which give constant overall response through the tape machine using simple networks in both record and playback. The design at 15 ips has been very conservative with respect to overload capabilities, but the signal-to-noise ratio has been inadequate. Greater attention to the characteristics of the ear, the tape, and the music

would provide a system with a greater signal-to-noise ratio.

AMPEX engineers therefore devised a 15 ips equalization known as AMPEX Master Equalization (AME) wherein a post-emphasis is designed to minimize audible noise, and then the pre-emphasis is employed to make the overall system flat. AME admittedly trades overload margin for a lower noise level, and must be properly used to obtain the intended results without distortion. It is intended for professional use, such as the recording industry, and is not to be considered as supplanting the NAB standard for publicly released tapes.

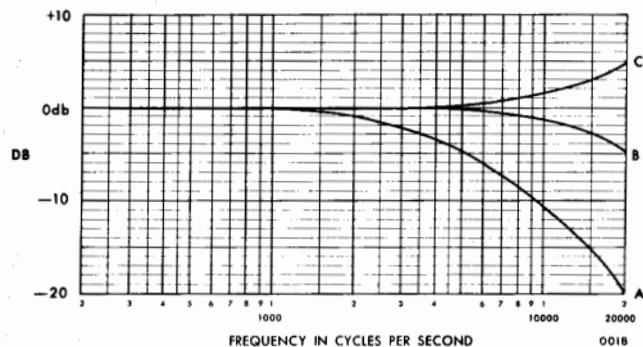

This graph shows how a flat overall frequency response is achieved. Curve A is an "ideal" record-reproduce response. Curve B is the result of adding the standard NAB post-emphasis to the ideal response. Curve C indicates the amount of record pre-emphasis needed to achieve flat response. As the post-emphasis curve is established as a standard, any deviation from the ideal response must be accompanied by a change in pre-emphasis.

## FREQUENCY RESPONSE

### Head-To-Tape Contact

A knowledge of the effects of losing good head-to-tape contact will help us realize the importance of

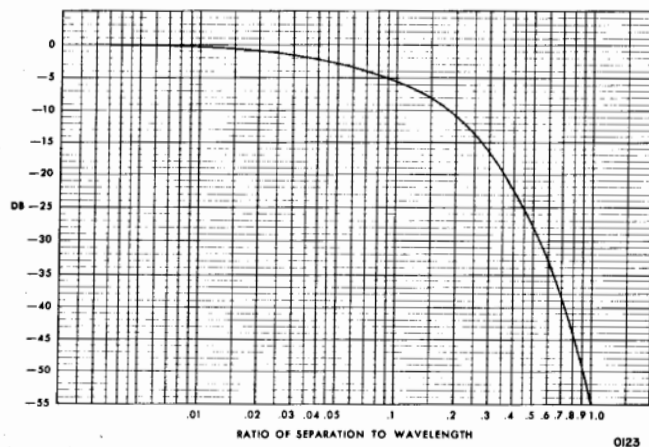

This curve indicates the result of poor head-to-tape contact as a function of the amount of separation and the signal wavelength.

maintaining good contact. The predicted loss in separating the reproduce head from the surface of the medium is 54.6 db per wavelength separation. Thus at short wavelengths, say 1/2 mil (15,000 cps at 7 1/2 ips), it takes very little space to result in a 5 db loss in signal strength. When we remember that commensurate losses also could occur in the record mode, it becomes evident why good contact is a major consideration in achieving top performance in a magnetic tape recorder.

### High Frequency Response

In audio applications, and at tape speeds normally used in professional work, the high frequency response is almost entirely limited by the tape and magnetic heads, in what are referred to as "wavelength losses". Despite numerous tomes attempting to explain these losses they are as yet not fully understood, and we would be presumptuous if we attempted any explanation on this plane.

As our high frequency requirement rises — in video or instrumentation applications — or as our tape speed is lowered, we enter a region where the dimensions of the reproduce head gap, and the resonant frequency of the heads become important factors.

### Gap Effect

As shown on the accompanying diagram, when the recorded frequency rises to a degree where the reproduce head gap intercepts a complete wavelength of the signal on the tape, there can be no difference in flux magnitude across the gap, and the head output will be reduced to zero. Practically, this will occur at the "effective" gap length, which is slightly longer than the physical length. For all practicable purposes this effect causes the head output at this frequency and above to be useless.

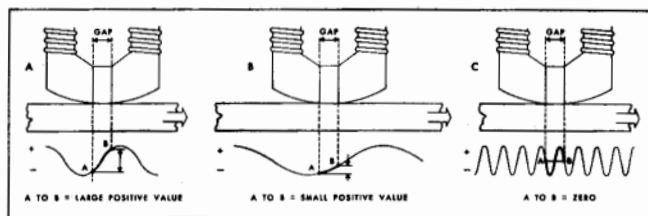

In this illustration sinusoidal waveforms are used to denote the average state of tape magnetization and to indicate how the reproduce head gap derives a large output from a medium wavelength signal (A), a small output from a long wavelength signal (B), or no output when the wavelength equals the gap length (C).

Two methods may be employed to counteract this "gap" effect — either the gap can be made smaller or the record-reproduce tape speed can be increased. We can reduce the dimension of the gap only so far and retain adequate signal levels and realistic manufacturing tolerances; as this point is reached any further extension of high frequency response must be accompanied by a corresponding increase in tape speed.

The gap effect may be negligible when we are dealing with audio frequencies at 7½ or 15 ips tape speeds. For instance, the AMPEX reproduce heads have a gap of 0.2 mil, and the gap loss is unimportant at the wavelengths involved. However, at lower tape speeds, or for instrumentation or video applications where the high frequency requirements are greatly extended, it becomes a serious limitation.

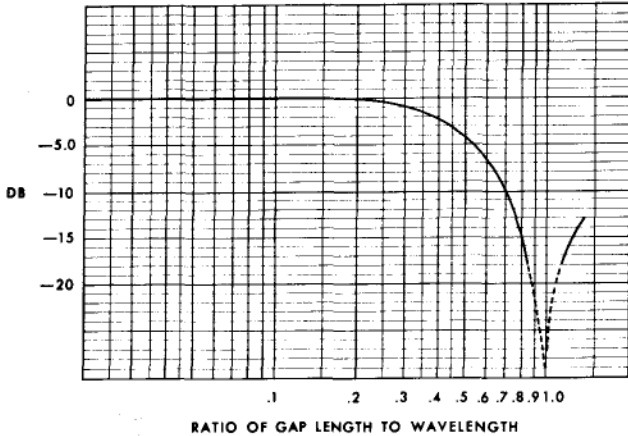

The loss that occurs when the wavelength of the recorded signal approaches the length of the reproduce head gap is indicated on this graph.

#### Head Resonance

The coils of the heads are inductances which will resonate with lumped or distributed capacity in the circuit. At the resonant frequency of the reproduce head there is an increased output, but a sharp drop of approximately 12 db per octave occurs directly after this point. Thus the resonant frequency must normally be outside the pass band of the system, or placed (in video and data recorders) at the extreme upper limit so that it actually provides a shelf at the point of resonance to extend the response.

As circuit capacitance is reduced to an absolute minimum, only one way remains to place the point of resonance at a higher frequency, and that is to reduce the inductance of the head coil by employing a lesser number of turns of wire. A reduction in the number of turns, however, will reduce head output over the entire frequency range, so a compromise design must be provided.

#### Low Frequency Response

Low frequency response is almost completely a function of the effects generally known as "head bumps". This effect will occur in the reproduce mode at the low frequencies, as the recorded wavelength of the signal on the tape begins to approach the overall dimension of the two pole pieces on either side of the head gap. In effect, the two pole pieces now begin to act as a second gap, because they can pick up magnetic flux on the tape quite efficiently.

As our frequency decreases we may start to notice bumps and dips in the output of the head. The largest

bump will occur when one-half wavelength of the recorded signal equals the combined distance across the two pole pieces, but there will be progressively smaller bumps at 1½ wavelengths, 2½ wavelengths, etc. Similarly the largest dip will occur when one complete wavelength of the recorded signal equals the distance across the pole pieces, and again there will be progressively smaller dips at 2 wavelengths,

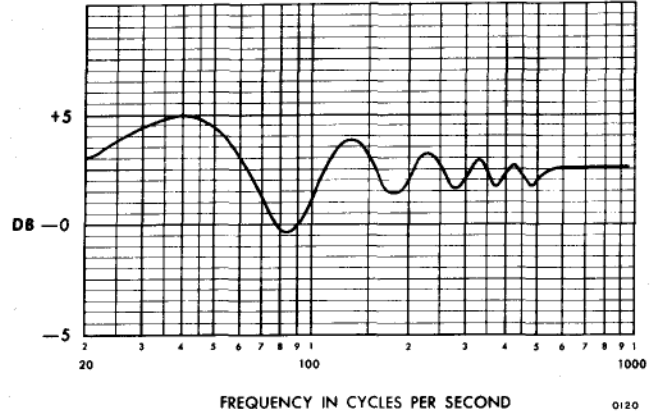

Uncorrected head bump curve produced artificially by excessive tape wrap around an experimental reproduce head.

3 wavelengths, etc. So as our frequency goes lower and lower the bumps and dips will get bigger and bigger. Below the largest bump, at ½ wavelength, the output rapidly falls to zero.

It is interesting to note the similarity between the head bumps at the low frequencies and the gap effect at the high frequencies. When the head gap intercepts a complete wavelength we have no output; when the pole pieces intercept a complete wavelength we have a decline in output. The largest theoretical output occurs when the head gap intercepts one-half wavelength, there is an increase in output when the pole pieces intercept one-half wavelength. There is of course one great difference — increasing the tape speed diminishes the gap affected by spreading the signal over a greater length of tape, but decreasing the tape speed diminishes the head bumps by shortening the wavelength on the tape. At 15 ips tape speed the head bump is a rather serious problem, at 7½ ips the problem is reduced, and at 3¾ ips it has practically disappeared.

Good engineering design is the only way to alleviate the head bump situation. The physical configuration of the pole pieces and shields, and the angle of wrap of the tape around the head, can be designed so that the extremities of the pole pieces are farther from the tape and cannot pick up the signal so readily. An ideal solution, but rather impractical in today's compact equipments, would be to make the pole pieces so large that no problem would exist down to 10 or 15 cps.

In any event, the head assembly must be designed so that the head bumps occur at the lowest possible frequency, so that if possible no more than one

smooth bump or dip is in the audio spectrum. We can then compensate for this in the electronic circuits.

#### Additional Factors For Multi-Channel Recording

For stereophonic recording we must add two additional factors — precise phasing between channels and adequate cross-talk rejection.

#### Phasing Between Channels

The directional quality of stereophonic sound, or of any sound we hear, is dependent on the ability of the brain to distinguish subtle differences in phase and intensity as sound waves arrive first in one ear and then the other. If, in storing and reproducing stereo sound, we destroy the normal phasing between channels, it will result in a most confusing end product.

When we are recording largely independent sources on separate tracks of the tape, phasing is not too much of a problem. When those sources are not isolated — for example, when we are recording an instrument on two channels simultaneously to achieve a center effect — it becomes more important. And when we are mixing and recombining in the recording industry to produce two channel tapes from a three channel master, it becomes quite critical.

Phasing between channels is a function of the alignment of head gaps and the wavelength involved. Tolerances are most critical at slower tape speeds.

At the present state of the art, AMEPX multi-channel heads are manufactured so that all record or reproduce head gaps will fall within two parallel lines spaced 0.2 mils apart.

#### Crosstalk Rejection

Crosstalk rejection acts the opposite of phasing, in that it becomes more critical as sources on separate channels become more independent. When adjacent tracks are completely independent, such as in our present 4 track 1/4-inch tapes, crosstalk rejection on the order of 60 db in the midrange is adequate. Regular stereo tapes (2 track on 1/4-inch tape) require less rejection.

Adequate shielding between heads, and maximum track spacing in conjunction with the practical compromises we have already covered (see Signal-to-Noise) are our major means of combating crosstalk. This entails a typical spacing between tracks of 70-100 mils.

#### Head Assemblies

Finally, we must take a quick look at the magnetic heads. We have already seen the precise tolerances we must secure in aligning the different heads in a stack. The same careful precision must be taken to ensure the straightness of the individual gaps and their perpendicularity, if we are to achieve interchangeability of tapes.

In older, sandwich-type heads it was practically impossible to achieve the required tolerances, with

the result that the master tapes could consistently be reproduced only on the equipment that recorded them and then not too successfully because of differences in the record and reproduce head stacks. Quoted specifications were thus at times inaccurate when tapes from one equipment were played back on another.

The introduction of cast type heads, with tolerances held by mechanical considerations, has alleviated this problem — but only recently. Today we should be able to play back tape from any recorder on any other comparable equipment, and do it within quoted specifications.

The sandwich type heads were constructed by completely assembling each individual head intended for multi-channel use, stacking those heads one on top of the other, then bolting them together. It was impossible to produce heads with consistent characteristics; you can see that even a slight difference in tightening the bolts that held the head together could cause gaps to be misplaced with respect to each other or the azimuth of each head to be misaligned.

Cast heads are constructed by assembling, potting, and lapping the pole pieces separately. The two pole pieces are then placed in a rigid fixture and potted together. Using this technique, all gaps can be aligned within 0.2 mils with a maximum tilt of less than three minutes from the perpendicular.

#### BASIC ADJUSTMENTS ON MAGNETIC TAPE RECORDERS

There are certain basic adjustments usually provided on professional quality magnetic tape recorders.

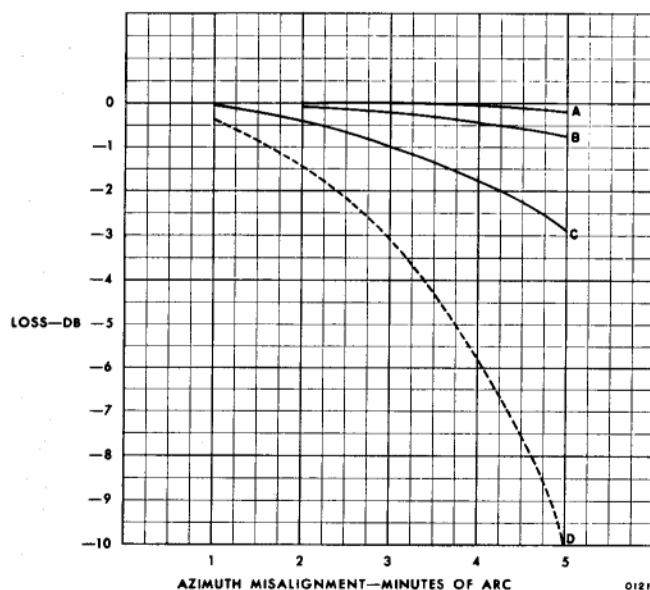

This graph shows the effect of head azimuth misalignment. Curves A, B, and C were taken using a 75 mil gap width at wavelengths of 1, .5, and .25 mil respectively. In Curve D a gap width of 250 mils and a wavelength of .5 mil were used.

Underlying each of these adjustments is at least one of the principles of magnetic recording we have been discussing.

#### *Head Azimuth Adjustment*

It is important that the heads be aligned so that the gaps are exactly perpendicular to the top and bottom edges of the moving tape. If the gaps are slanted across the width of the tape we have created a situation where the signal reproduced from the upper part of the tape is out of phase with the signal from the lower part of the tape. This phasing condition causes a cancellation of signal, accentuated at the higher frequencies. Of course, if the record and reproduce head gaps on an individual single channel recorder were exactly parallel, it would make little difference if they were slanted slightly, *as long as the equipment played only those tapes it had recorded and as long as those tapes were not to be reproduced on other equipment.* But as soon as we want interchangeability of tapes from machine to machine we must establish a universal head alignment. Also, as we have seen, we cannot tolerate phasing problems in stereophonic equipment.

The best method in procuring this alignment is to use a standard alignment tape, produced under stringent laboratory conditions. This tape will be recorded with a head alignment signal, and the reproduce head is adjusted to give a maximum output of this signal. The standard tape is then removed, and the record head is aligned so the its recordings result in a maximum output on the previously aligned reproduce head. Both heads are thus set to a universal standard.

#### *Level Adjustments*

The volume level in reproduction is strictly a matter of personal preference, but the record level must be accurately calibrated if optimum noise and distortion are to be maintained. This is again most easily accomplished by using a standard alignment tape to set the reproduce level to a reference amplitude. The record level is then calibrated to produce this reference playback level.

The record calibration *can* be set by using a distortion meter to measure the third harmonic content. Normal record level is usually at a 1% harmonic distortion level, so it can be adjusted to that value. However, distortion meters are seldom available in practice, the record level is nominal, and different tapes may vary by  $\pm 1$  (or even  $\pm 2$ ) db. Therefore the standard alignment tape procedure is certainly adequate.

#### *Equalization Adjustment*

A series of tones will be recorded on the standard alignment tape so that the reproduce amplifier response can be set on curve.

The rising characteristic of the reproduce head is not only the consideration in achieving an overall flat response; there are certain wavelength losses

which, as we have already stated, are not fully understood. Therefore, a certain variable pre-emphasis is employed in the recording process, which is adjusted to achieve a flat response when the reproduce amplifier is set on a standard curve.

The easiest way to set the playback response on curve is to play a standard alignment tape, and adjust the variable equalizing components for a flat response as the precisely recorded tones are reproduced. Another widely used method is to use an audio oscillator and a vtvm to actually follow the response curve provided with the equipment; this, however, does not allow for variations in head characteristics.

The record pre-emphasis is then adjusted for a flat overall frequency response through the previously standardized reproduce system.

#### *Record Bias Adjustment*

We make the high frequency bias adjustment using a signal of specific wavelength (normally 15 mils — 1000 cycles at 15 ips, 500 cycles at  $7\frac{1}{2}$  ips, etc.) at the normal tape operating level. The bias is set, while recording this signal, to achieve a maximum output.

Because the output vs bias current is very broad near the peak bias current setting, the adjustment is simplified by increasing the bias current until the output drops  $\frac{1}{2}$  db then decreasing the bias until the output again drops  $\frac{1}{2}$  db; the correct setting is the average of the over- and under-bias.

The maximum amplitude point at the given wavelength will give low distortion and reasonable short wavelength losses. It is also comparatively easy to adjust and can be consistently repeated using simple test equipment.

Because the magnetization curve varies with different tapes, the bias voltage ideally should be adjusted each time the tape is changed — particularly if the change is to a tape from a different manufacturer. However, this would normally be done only when extreme fidelity was required, such as when recording a master tape for a commercial recording company. Usually, a carefully adjusted "average" bias setting will produce excellent results with a wide variety of tapes.

#### *Tape Tension*

As indicated in our discussion of Tape Transport Design, the tension of the tape as it winds through the system is very important. Proper tape guiding is, to a large degree, dependent on correct tensions. A good tape pack on the takeup reel is also determined by this function. And very importantly, if tape is stored under excessive tension, it will tend to stretch; also the phenomenon known as "print through" (where the magnetic signal on one layer of tape on the reel is transferred to adjacent layers) will be accentuated.

Tape tension control in professional quality equipment is normally adjusted by varying the resistance





*Duplicating equipment at Magnetic Tape Duplicators, Hollywood. Ampex duplicating equipment produces copies of master tapes at high speed with as many as ten copies produced with each run of the master.*

in series with the reel motor (or clutch) and thus the torque of the turntable. Measurement is made with a spring-type scale and adjusted to the manufacturer's specifications.

#### *Braking Adjustment*

Our brakes control our stopping function, and must be correctly adjusted if we are to stop tape motion without throwing loops (all tape tension imparted by the turntables is lost the moment we press the stop button). So we must always have a greater braking force acting on the turntable which is supplying the tape than on the turntable reeling in the tape.

Mechanical adjustments, where we control braking forces, are provided for each turntable. In some cases we must adjust for each direction of rotation of the reel; in others, we will adjust only for one direction of rotation and the other direction will be automatically acceptable.

#### *Demagnetization*

If any of the components in our tape threading path become permanently magnetized, we might partially erase any high frequencies recorded on the tape. If magnetization occurs at our magnetic heads we can at least expect an increase in noise level. Some means of demagnetizing these components must therefore be available.

Demagnetization is usually achieved through a small, hand type, device that is readily available on the open market or from tape equipment manufacturers. It is easily operated and very effective when used correctly.

#### *Noise Balance*

One of our greatest potential sources of noise is in

our bias and erase oscillator. If there is any asymmetry from this circuit it will show up as a d-c component — capable of permanently magnetizing our record and erase heads and causing distortion and noise in our recorded signal.

When we use a push-pull oscillator we can balance out any asymmetry by using a variable cathode resistor common to each tube in the circuit. This resistor is adjusted for a minimum noise as read at the output of the equipment.

#### *Cleaning*

It does little good to buy professional quality equipment if we allow accumulations of matter to build up on the tape transport. One of the easiest, one of the most important, and probably one of the most neglected maintenance procedures is the cleaning of the transport.

The major source of foreign material on the transport is the magnetic tape. Oxide and lubricant from the tape will gradually accumulate on the components in the tape threading path, and if it is not removed our equipment will not operate satisfactorily — even though everything else on the recorder is in perfect condition. For example, if the accumulation is on our precisely machined capstan (or the capstan idler) we will have excessive flutter. If it is on a tape guiding component it is apt to cause a vibration in the tape — similar to the vibration that occurs when we pluck a violin string — and again, we will have excessive flutter. If it accumulates on the heads, the tape will not maintain good contact, and our recorded level and/or frequency response will suffer.

So we must clean the transport on a regularly scheduled basis, with each component in the tape threading path receiving attention. *But we must be*



*Magnetic film transports are used extensively in the motion picture industry for dubbing master sound tracks. Here is the Ampex 35-mil film transport installation at Glen Glenn Sound Studios, Hollywood.*

careful to use only the cleaning agent recommended by the manufacturer of the equipment. This is extremely important in cleaning the heads, as some agents will damage those precise assemblies.

## CONCLUSION

In this discussion, we have tried to present the principles of magnetic recording in a way that will aid the persons who operate and maintain the equipment. Most aspects of the process have been merely introduced, but if we have succeeded in imparting some realization of what is taking place in our alignment and maintenance procedures the discussion

will have been worthwhile.

This industry has been just born in the commercial sense, but it is already expanding. Today we are using magnetic recording not only in audio, but also in digital and analog instrumentation applications. And recently we entered the age of magnetic photography when we started putting the television picture on tape. The principles involved are the same, whether it is VIDEOTAPE\* recorder, a theater sound system, a computer application, or a home installation. We hope this discussion has aided you in understanding those principles.

\*T.M. AMPEX Corporation

---

## BIBLIOGRAPHY

- E. D. Daniel and P. E. Axon: The Standardization of Magnetic Tape Recording Systems; The B.B.C. Quarterly, Vol. VIII, No. 4, Winter 1953-54.
- E. D. Daniel and P. E. Axon: The Reproduction of Signals Recorded on Magnetic Tape; The Proceedings of the Institute of Electrical Engineers, Vol. 100, Part III, No. 65, May 1953.
- E. D. Daniels: The Influence of Some Head and Tape Constants on the Signal Recorded on a Magnetic Tape; The Proceedings of the Institution of Electrical Engineers, Vol. 100, Part III, No. 65, May 1953.
- E. D. Daniel, P. E. Axon, and W. T. Frost: A Survey of Factors Limiting the Performance of Magnetic Recording Systems; Journal of the Audio Engineering Society, Vol. 5, No. 1, January 1957.
- J. G. McKnight: The Frequency Response of Magnetic Recorders for Audio; Journal of the Audio Engineering Society, Vol. 8, No. 3, July 1960.
- J. G. McKnight: Signal-to-Noise Problems and a New Equalization for Magnetic Recording of Music; Journal of the Audio Engineering Society, Vol. 7, No. 1, January 1959.
- F. G. Lennert: Equalization of Magnetic Tape Recorders for Audio and Instrumentation Applications; Trans. IRE-PGA, AU-1, No. 2, March 1953.
- R. J. Tinkham: Solution to Some Problems in Making Master Tapes; Journal of the Audio Engineering Society, Vol. 5, No. 2, April 1957.
- G. B. Goodall: The Videotape Recorder; International Projectionist, April to August 1959 issues.
- R. J. Tinkham: Magnetic Recording Media Considerations for Improving Masters and Dubs; Journal of the SMPTE, Vol. 67, October 1958.
- John G. McKnight: The Distribution of Peak Energy in Recorded Music, and Its Relation to Magnetic Recording Systems; Journal of the Audio Engineering Society, Vol. 7, No. 2, April 1959.
- R. A. Isberg: The 120-ips Tape Duplicator for Four-Track Commercial Stereo Tapes; Journal of the Audio Engineering Society, Vol. 8, No. 2, April 1960.
- C. B. Stanley: How Magnetic Tape Characteristics Affect System Performance and Determining Optimum Bias; Ampex Publication, Technical Information Brochure No. 4.
- C. B. Stanley: An Approach to Quantative Methods for Evaluation of Magnetic Recording Performance; Ampex Publication, Technical Information Brochure No. 1.
- W. M. Fujii, G. Rehkla, J. McKnight, W. Miltenberg: Multi-Channel Recording for Mastering Purposes; Journal of the Audio Engineering Society, Vol. 8, No. 4, October 1960.
- W. Earl Stewart: Magnetic Recording Techniques; McGraw-Hill Book Co., Inc; 1958.
- S. J. Begun: Magnetic Recording; Rinehart Books, Inc; 1949.
- W. K. Westmijze: Studies on Magnetic Recording; Phillips Research Laboratories, Reprinted from Research Reports 8, Reprint R213, R214, R217, R222.