

AMPEX

AUDIO TAPE RECORDER

ATR-800



Ampex ATR-800: A World Class Performer

The ATR-800 is a true international audio tape recorder in every sense of the word. It provides both NAB and IEC recording standards with the performance, quality, and important features you've come to expect from Ampex.

Ruggedly built, sophisticated yet easy to use, this newest member of the Ampex family of audio recorders is designed for the radio and television broadcaster as well as the recording studio owner who wants the most for his money.

The ATR-800 is available in mono, stereo, 2, and 4 track versions and offers an impressive array of operation and editing features — many of which you'd expect to find only as options on other machines. Standard features include continuously variable shuttle, three speed and variable speed operation, built-in cue amplifier, single point search-to-cue and electronic tape timer. Numerous options and accessories further enhance the recorder's capabilities.

A PRODUCT OF TRADITION

In 1946 we introduced our first audio tape recorder. Since then, Ampex audio and video products have earned a worldwide reputation for superior quality and technical excellence.

Now with the ATR-800, we proudly offer a machine that carries on this tradition.



ATR-800 is a world machine with switchable NAB/IEC operation, optional DIN hubs, universal power supply, and appropriate components and performance to meet worldwide requirements.

ATR-800's MANY FEATURES

Performance: Designed to meet international broadcasting and recording standards. Ensures that the recorded product has the highest quality attainable.

Designed for editing: All important edit modes are included; i.e., Dump Edit and Hands-on reel editing. The head assembly is wide open, making for unequalled accessibility to the heads for marking and cueing.

Continuously Variable Shuttle: Provides continuous control of tape speed and direction when doing manual cueing. Speeds the manual cueing operation.

Cue Amplifier: Allows monitoring of any or all channels of a tape at the machine during editing operations or while it is being cued.

Recessed controls: All controls are recessed below tape level, preventing tape snag and speeding editing operations.

Electronic Tape Timer: Provides accurate timing of recorded segments for all machine speeds in hours, minutes, and seconds.

Left or right control panel mounting: Transport controls can be mounted to the left or right side of the machine to accommodate left or right handed operating and editing procedures.

Switchable NAB and IEC machine setup: At the flip of a switch, the recorder converts between NAB and IEC setup. This includes bias as well as equalization.

Three speed operation: All machines are shipped 7½, 15, and 30 in./sec and field convertible to 3¾, 7½ and 15 in./sec. There is NAB and IEC setup for each of the three speeds.

Fader start: Provides remote start and stop of a cued tape from the fader switch on the mixing console.

Handles all standard reel configurations: Capacity for 10½ inch NAB and the plastic EIA (Cine) reels is standard. Easily converts to 30 cm (11.8 in) DIN hubs with an accessory DIN hub kit.

Universal power supply: Easily convertible to all world power standards.

Stereo/Mono level switching: Maintains proper output level when playing mono tapes on stereo format machines.

VU and Peak metering: Provides switch-selectable ANSI VU or EBU peak metering ballistics.

Single Point Search-To-Cue: Provides automatic and quick return to a defined cue point. Uses the electronic tape timer for exceptional accuracy.

Variable Speed Operation: Allows recording and playback up to ±10% of nominal speed. Corrects for recordings made off speed or allows for special effects.

Quick change head assembly: Head assembly is quickly removed or installed by one quarter-turn fastener. The head assembly, when changed, requires no mechanical realignment. Speeds maintenance and format conversions.

Microprocessor control: Transport is under the full control of the microprocessor system, ensuring safe, gentle, and foolproof tape handling.

Fully closed loop servos: Closed loop servos for the capstan and spooling motors provide exceptionally low wow and flutter and controlled tape tension in all transport modes. Closed loop servos ensure proper tape handling for all reel configurations without reel size or type switching.

Pick Up Record Capability (PURC)™: Compensates for the distance between the erase and record heads. Prevents gaps and overlap when recording over a previously recorded tape.

Ceramic tape guides: Ceramic tape guides provide tape guiding that does not deteriorate with time. Precision alignment of the tape deck is maintained over years of usage.

No fans: The recorder is cooled without the use of fans, providing low ambient noise and immunity from fan failure. No fan screens to clean.

Phase Compensated Record Equalization: Ensures highest quality recorded audio through preservation of the audio waveform.

Controllable for remote cueing and synchronizing: All necessary transport controls and signals are available through connectors, allowing remote cueing and synchronizing with other audio and video recorders.

Serviceability: Major electronic assemblies are accessible from the front of the recorder in both the rack mount and console versions. These



electronic assemblies are plug-in and serviceable on extender cards.

Easy format conversion: Easily converts from one channel to two to four, or back. All machines are easily convertible to other formats in the field.

Rack mountable: All ATR-800s are supplied with the necessary hardware to rack mount in a standard EIA 19 inch equipment rack. Standard mounting dimensions are used for adaptability to custom rack mount installations.

FAST, EASY EDITING

The ATR-800 was designed for editing. It features an extra wide head assembly for easy access to the head area, recessed head gate and transport controls to prevent tape snag, and a continuously variable



The ATR-800 is available in quarter inch and half inch versions, with mono, stereo, two track, and four track capability. Tabletop console and rollaround pedestal versions are available.

shuttle. Hands-on-reel and tape dump modes have been incorporated into the transport design for convenient manual editing.

Editing is further enhanced by an accurate electronic tape timer which provides timing of recorded segments for all speeds in hours, minutes, and seconds.

In addition, a single point search-to-cue allows automatic return to a previously defined cue or edit point. Segments can be rehearsed over and over from exactly the same starting point at the touch of a single button.

Unique to the ATR-800 are its interchangeable transport control panels. The panels can be mounted either to the left or right side of the machine to accommodate left or right-handed operating and editing procedures.

QUICK CHANGE HEAD ASSEMBLY

With the ATR-800, Ampex introduces a new quick change head assembly. The unit is easily installed with one quarter-turn fastener. Once in place, no further mechanical realignment is needed. The high-precision record and reproduce heads are of metal-laminated construction to ensure extra long life and high performance. Space is provided for an additional fourth head for playback of two different tape formats without a head assembly change. Ceramic tape guides are used to ensure precision alignment of the tape deck over years of usage. A scrape flutter idler is standard with all head assemblies.

SERVICING MADE EASY

Plug-in Printed Wiring Assemblies (PWAs) are easily accessed from the front when the recorder is rack mounted or in a console. The high quality PWAs are glass-laminated for durability and reliable service.

Calibration controls for the system's electronics are conveniently placed at the edge of the PWAs, permitting normal machine alignment adjustments without the use of extender cards.

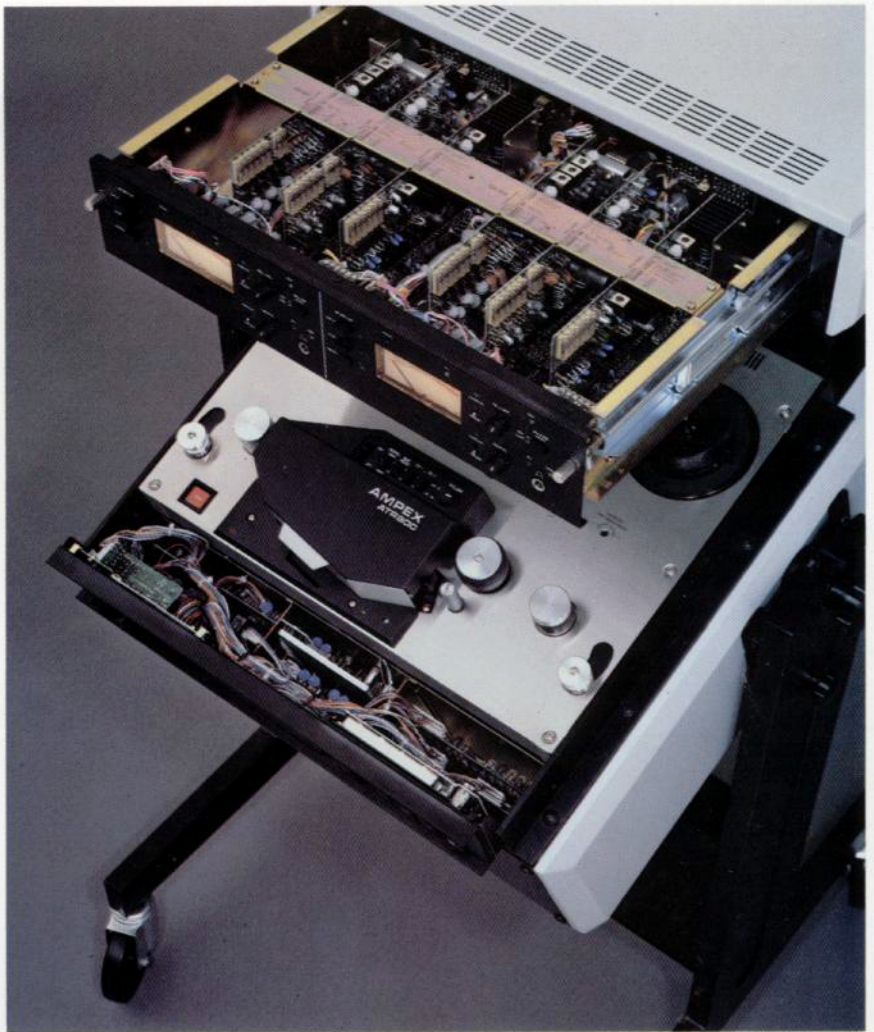

OPTIONS AND ACCESSORIES

Console

Provides for enclosed tabletop operations.

Pedestal

Provides rollaround operation of console mounted recorder.

Neopilot Tone Playback Kit

Provides playback of tapes with the neopilot tone reference signal. Includes appropriate head stack and pre-amp electronics.

Microphone Pre-amp

Allows recording of microphone level signals without an external pre-amplifier.

Tape Marker

Located directly in front of the reproduce head, allows for direct marking onto the tape at the push of a button.

Tape Cutter

At the touch of a button, the tape cutter safely and accurately cuts the tape at the appropriate angle for splicing. Located between the capstan and the tape timer idler.

Tape Velocity Indicator Kit

Provides readout of the tape velocity in percent of nominal speed when the recorder is in the variable speed mode.

Remote Control

Provides remote control of all normal transport functions including Search-to-Cue, and tape time display.

Running Time Meters

Provides indication of the operating time of the recorder for periodic and preventative maintenance.

Noise Reduction Interface Kit

Provides switching for the Dolby¹ and dbx² systems when the recorder goes between record and play modes.

Splicing Block

Standard splicing block which can be mounted on top of the head assembly or in front of the head gate.

Din Hubs

Easily mountable hubs which allow the use of up to 30 cm (11.8 in) DIN pancake tapes. The hub holddown remains secure to the turntable in

both the holddown and free positions.

Fourth Head Stack

All standard one-quarter inch formats, including one-quarter track, are available for mounting in the fourth head position. A switch is supplied standard with every 2-channel machine to switch between the normal reproduce head and the fourth head.

Spares Kits

Spares kits are available to expedite servicing.

Extender Card Kit

Contains extender cards necessary to service printed wiring assemblies in the recorder.

Head Assemblies

Standard head assemblies are available for quick conversion of the recorder between recording formats for quick servicing or replacement.

1 TM, Dolby Laboratories

2 TM, dbx Inc.

- 1** Continuously variable shuttle
- 2** Cue amplifier
- 3** Fully servoed operation
- 4** Electronic tape timer with single point search-to-cue
- 5** Three speeds with variable speed operation
- 6** Switchable between NAB and IEC setup
- 7** Recessed controls



ATR-800 PRELIMINARY SPECIFICATIONS

INPUTS

Balanced, Floating
 Input Impedance: 10 K Ohms
 Max. input level: +36 dBm
 Microphone: Balanced, 600/150 Ohms, -70 dBm to -20 dBm for reference level.

OUTPUTS

Balanced, Floating
 Output Impedance: Less than 30 Ohms, 30Hz to 15KHz
 Max. output level: +28 dBu into 600 Ohms
 *0dBu = 0.775v
 Headphone: 600 Ohms or higher

FREQUENCY RESPONSE

Speed	Within ±.75 dB	Within ±2 dB
30 in/sec	100 Hz - 20 KHz	50 Hz - 24 KHz
15 in/sec	100 Hz - 15 KHz	30 Hz - 20 KHz
7.5 in/sec	100 Hz - 10 KHz	30 Hz - 15 KHz

SIGNAL-TO-NOISE RATIO

NAB Equalization:

Tape Speed	Track Format	30-18 KHz Unweighted	ANSI "A" Weighted
30 in/sec (AES)	Full	76 dB	80 dB
30 in/sec (AES)	Two and four	71 dB	75 dB
30 in/sec (AES)	Stereo	72 dB	76 dB
15 in/sec	Full	75 dB	79 dB
15 in/sec	Two and four	70 dB	74 dB
15 in/sec	Stereo	71 dB	75 dB
7.5 in/sec	Full	74 dB	78 dB
7.5 in/sec	Two and four	69 dB	73 dB
7.5 in/sec	Stereo	70 dB	74 dB

Measured with respect to 1040 nWb/m when using Ampex 456 tape or direct equivalent.

CONSOLE / PEDESTAL

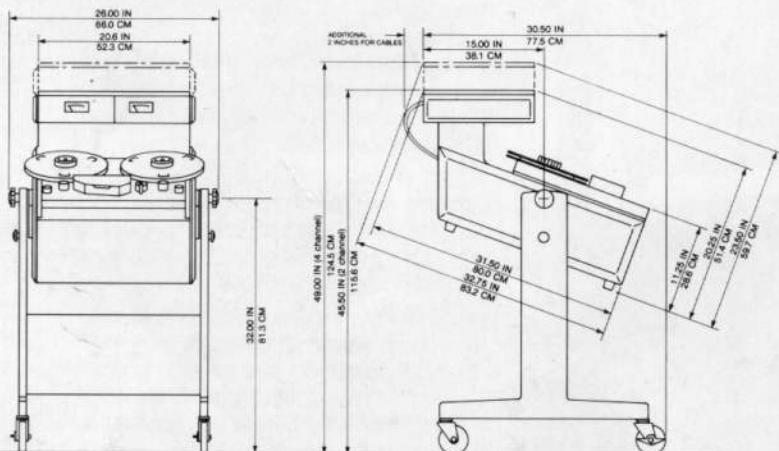

DISTORTION

Even Order Distortion at 1 KHz:
 Less than 0.2% at a recorded flux level of 1040 nWb/m using Ampex 456 tape or equivalent at 500 Hz.
 Third Harmonic Distortion at 1 KHz:
 Less than 0.3% at a recorded flux level of 370 nWb/m using Ampex 456 tape or equivalent.
 SMPTE Intermodulation Distortion:
 Less than 1% at a recorded flux level of 370 nWb/m using Ampex 456 tape or equivalent.

RECORD/REPRODUCE CROSSTALK

Two and Four track:
 -60 dB at 1 KHz
 -50 dB, 100 Hz - 12 KHz
 Stereo:
 -55 dB at 1 KHz
 -45 dB, 100 Hz - 12 KHz

REWIND TIME

Fast wind: Less than 80 sec for 2400 ft. reel

WOW AND FLUTTER

Speed	ANSI S4.3/DIN 45507 Peak Weighted	ANSI/DIN Peak Unweighted
7.5 in/sec	.06%	.12%
15 in/sec	.05%	.10%
30 in/sec	.04%	.08%

ELECTRONIC TAPE TIMER

Tape driven, reads in hours, minutes and seconds.

Weight:

Transport — 103 lbs. (47 kg) Console, 4 channel — 48 lbs. (22 kg)
 Electronics module Pedestal — 44 lbs. (20 kg)
 1 & 2 channel — 20 lbs. (9 kg)
 Console, 2 channel — 43 lbs. (19.5 kg)

RACK MOUNT

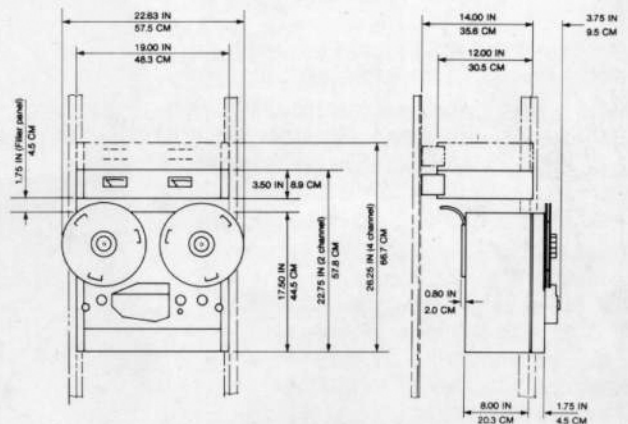

U.S. Field Offices In: CALIFORNIA, Cupertino (408) 255-4800; Glendale (213) 240-5000 • GEORGIA, Atlanta (404) 451-7112 • ILLINOIS, Arlington Heights (312) 593-6000 • KENTUCKY, Louisville (502) 239-6111 • MARYLAND, Bethesda (301) 530-8800 • NEW JERSEY, Hackensack (201) 489-7400 (in New York 736-6118) • OHIO, Dayton (513) 254-6101 • TEXAS, Dallas (214) 637-5100 • UTAH, Salt Lake City (801) 487-8181 • WASHINGTON, Tukwila (206) 575-0156

Ampex reserves the right to make product and specification changes at any time without notice.

AMPEX

Ampex Corporation, Audio-Video Systems Division
 401 Broadway
 Redwood City, California 94063

International Offices and Representatives: ARGENTINA, Buenos Aires 46-2776, 46-7690, 45-6823 • AUSTRALIA, North Ryde (02) 887-3333 • BELGIUM, Nivelles 067/22.49.21 • BRAZIL, Rio de Janeiro (021) 274-8122 • CANADA, Bramalea (416) 791-3100 • COLOMBIA, Bogota 236-7855 • FRANCE, Paris 270.55.00 • GERMANY (FEDERAL REPUBLIC), Frankfurt (Main) 60580 • GREECE, Athens 6830611 • HONG KONG, Kowloon 3-678051-3, 3-7210323-4 • ITALY, Rome (06) 54-69-91 • JAPAN, Tokyo 03-264-7331 • MEXICO, Mexico City 539-68-70/71/72 • NETHERLANDS, Utrecht 030-61.29.21 • PUERTO RICO, Puerto Nuevo (809) 781-1985 • SINGAPORE, Singapore 2239241 • SPAIN, Madrid (91) 20.29.141 • SWEDEN, Sundbyberg 08/28 29 10 • SWITZERLAND, Fribourg 037-81.31.11 • UNITED KINGDOM, Reading, England (0734) 85200 • VENEZUELA, Caracas 782-3255

© 1981 Ampex Corporation
 Litho in U.S.A. — 10/81 — A915

Ampex Corporation • One of The Signal Companies